



Builder Rear Vent Direct Vent

Models: 33LDVR, 36LDVR,
39LDVR, 43LDVR

INSTALLER/CONSUMER SAFETY INFORMATION

**PLEASE READ THIS MANUAL
BEFORE INSTALLING AND USING
APPLIANCE**

WARNING!

**IF THE INFORMATION IN THIS
MANUAL IS NOT FOLLOWED
EXACTLY, A FIRE OR EXPLOSION
MAY RESULT CAUSING
PROPERTY DAMAGE, PERSONAL
INJURY OR LOSS OF LIFE.**

FOR YOUR SAFETY

**Installation and service must be
performed by a qualified installer,
service agency or the gas supplier.**

WHAT TO DO IF YOU SMELL GAS:

- Do not try to light any appliance.
- Do not touch any electric switch; do not use any phone in your building.
- Immediately call your gas supplier from your neighbor's phone. Follow the gas suppliers instructions.
- If you cannot reach your gas supplier call the fire department.

**DO NOT STORE OR USE
GASOLINE OR OTHER
FLAMMABLE VAPORS AND
LIQUIDS IN THE VICINITY OF THIS
OR ANY OTHER APPLIANCE.**

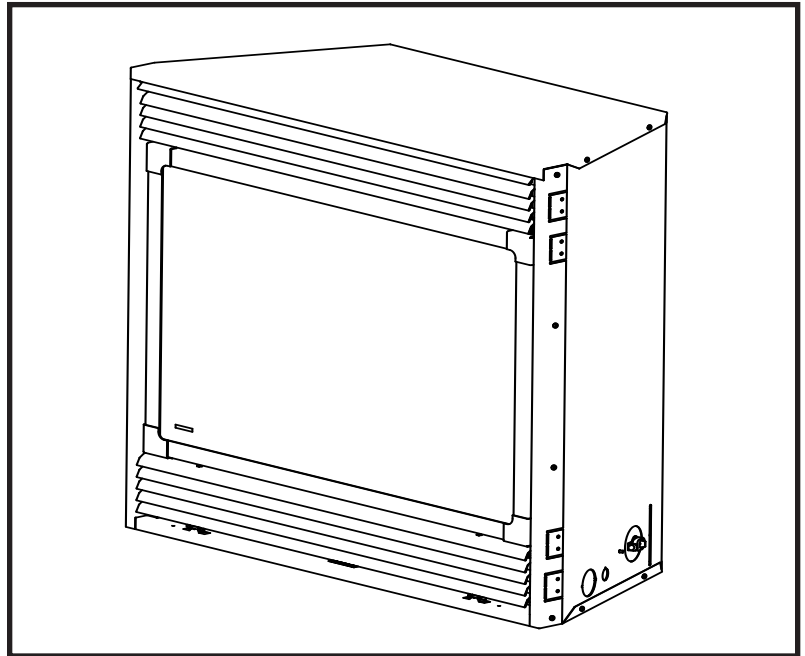

Installation Instructions and Homeowner's Manual



**INSTALLER: Leave this manual with the appliance.
CONSUMER: Retain this manual for future reference.**

Table of Contents

PLEASE READ THE INSTALLATION & OPERATING INSTRUCTIONS BEFORE USING APPLIANCE.

Thank you and congratulations on your purchase of a CFM Corporation fireplace.

IMPORTANT: Read all instructions and warnings carefully before starting installation.

Failure to follow these instructions fully may result in a possible fire hazard and will void the warranty.

Installation & Operating Instructions

| | |
|--|---|
| General Information, Cautions, Warning | 3 |
| Requirements for the Commonwealth of Massachusetts | 4 |
| Fireplace Dimensions | 5 |
| Locating Your Fireplace | 6 |
| Clearance to Combustibles | 6 |
| Mantels | 6 |
| Hearth | 7 |
| Framing and Finishing | 7 |
| Final Finishing | 7 |
| Gas Specifications | 7 |
| Gas Inlet and Manifold Pressures | 7 |
| High Elevations | 8 |
| Gas Line Installation | 8 |
| Remote ON/OFF Switch | 8 |
| Alternate Switch Location | 8 |
| EB-1 Electrical Box | 9 |
| Electronic Gas Control Valve | 9 |

General Venting Information

| | |
|---|----|
| General Venting | 10 |
| General Venting Information-Termination Location | 11 |
| General Information Assembling Vent Pipes | 12 |
| How to Use the Vent Graph | 13 |
| Rear Wall Venting Applications & Installation | 13 |
| Vertical Sidewall Applications & Installation | 15 |
| Below Grade Installation | 18 |
| Vertical Through-the-Roof Applications & Installation | 19 |
| Venting Components | 22 |

Operating Instructions

| | |
|--|----|
| Glass Information | 23 |
| Louvre Removal | 23 |
| Window Frame Assembly Removal | 23 |
| Glass Cleaning | 23 |
| Installation of Logs, Lava Rock & Ember Material | 24 |
| Flame & Temperature Adjustment | 26 |
| Flame Characteristics | 26 |
| Lighting and Operating Instructions | 28 |
| Troubleshooting | 30 |
| Fuel Conversion Instructions | 32 |

Maintenance

| | |
|--|----|
| Cleaning the Standing Pilot Control System | 33 |
|--|----|

Replacement Parts

Optional Accessories

| | |
|---------------------------------|----|
| Fan Kits | 37 |
| Ceramic Refractory Lining | 38 |
| Remote Controls | 38 |
| Trim Kits | 39 |
| Screen Door Kits | 39 |
| Filigree Louvre Kits | 39 |

Warranty

Energide

Installation & Operating Instructions

This gas fireplace should be installed by a qualified installer, preferably NFI or WETT (Canada) certified, in accordance with local building codes and with current CSA-B149.1 Installation codes for Gas Burning Appliances and Equipment. For USA Installations follow local codes and/or the current National Fuel Gas Code. ANSI Z223.1/NFPA 54.

FOR SAFE INSTALLATION AND OPERATION PLEASE NOTE THE FOLLOWING:

1. This fireplace gives off high temperatures and should be located out of high traffic areas and away from furniture and draperies.
2. Children and adults should be alerted to the hazards of high surface temperatures of this fireplace and should stay away to avoid burns or ignition of clothing.
3. **CAUTION: Due to high glass surface temperature children should be carefully supervised when in the same room as fireplace.**



4. Under no circumstances should this fireplace be modified. Parts removed for servicing should be replaced prior to operating this fireplace again.
5. Installation and any repairs to this fireplace must be performed by a qualified installer, service agency or gas supplier. A professional service person should be contacted to inspect this fireplace annually. Make it a practice to have all of your gas fireplaces checked annually. More frequent cleaning may be required due to excess lint and dust from carpeting, bedding material, etc.
6. Control compartments, burners and air passages in this fireplace should be kept clean and free of dust and lint. Make sure the gas valve and pilot light are turned off before you attempt to clean this fireplace.
7. The venting system (chimney) of this fireplace should be checked at least once a year and if needed your venting system should be cleaned.
8. Keep the area around your fireplace clear of combustible materials, gasoline and other flammable vapor and liquids. This fireplace should not be used as a drying rack for clothing, nor should Christmas stockings or decorations be hung on or around the fireplace.
9. Under no circumstances should any solid fuels (wood, coal, paper or cardboard etc.) be used in this fireplace.
10. The flow of combustion and ventilation air must not be obstructed in any way.
11. When fireplace is installed directly on carpeting, vinyl tile or any combustible material other than wood, the fireplace must be installed on a metal or wood panel extending the full width and depth of the fireplace.

12. This fireplace requires adequate ventilation and combustion air to operate properly.
13. This fireplace must not be connected to a chimney flue serving a separate solid fuel burning fireplace.
14. When the fireplace is not in use it is recommended that the gas valve be left in the **OFF** position.
15. These units have been approved for bedroom use.

WARNING: Check with your electronics manufacturer before installing a television or other electronic device above this fireplace.

**33LDVR / 36LDVR / 39LDVR / 43LDVR
Certified To**

**ANSI Z21.88-2005 / CSA 2.33-2005
Vented Gas Fireplace Heaters**

IMPORTANT:

PLEASE REVIEW THE FOLLOWING CAREFULLY
Remove any plastic from trim parts before turning the fireplace ON.

It is normal for fireplaces fabricated of steel to give off some expansion and/or contraction noises during the start up or cool down cycle. Similar noises are found with your furnace heat exchanger or car engine.

It is not unusual for your gas fireplace to give off some odor the first time it is burned. This is due to the curing of the paint and any undetected oil from the manufacturing process.

Please ensure that your room is well ventilated - open all windows.

It is recommended that you burn your fireplace for at least ten (10) hours the first time you use it. If the optional fan kit has been installed, place the fan switch in the "OFF" position during this time.

This appliance may be installed in an aftermarket permanently located, manufactured home or mobile home, where not prohibited by local codes.

This appliance is only for use with the type of gas indicated on the rating plate. This appliance is not convertible for use with other gases, unless a certified kit is used.

The LDVR has been approved for mobile home installations.

Proposition 65 Warning: Fuels used in gas, wood-burning or oil fired appliances, and the products of combustion of such fuels, contain chemicals known to the State of California to cause cancer, birth defects and other reproductive harm.

California Health & Safety Code Sec. 25249.6

Installation & Operating Instructions

Requirements for the Commonwealth of Massachusetts

All gas fitting and installation of this heater shall only be done by a licensed gas fitter or licensed plumber.

For all side wall horizontally vented gas fueled equipment installed in every dwelling, building or structure used in whole or in part for residential purposes, including those owned or operated by the Commonwealth and where the side wall exhaust vent termination is less than seven (7) feet above finished grade in the area of the venting, including but not limited to decks and porches, the following requirements shall be satisfied:

Installation of Carbon Monoxide Detectors

At the time of installation of the side wall horizontal vented gas fueled equipment, the installing plumber or gas fitter shall observe that a hard wired carbon monoxide detector with an alarm is installed on each additional level of the dwelling, building or structure served by the side wall horizontally vented gas fueled equipment. It shall be the responsibility of the property owner to secure the services of qualified licensed professionals for the installation of hard wired carbon monoxide detectors.

In the event that the side wall horizontally vented gas fueled equipment is installed in a crawl space or an attic, the hard wired carbon monoxide detector with alarm and battery back-up may be installed on the next adjacent floor level.

In the event that the requirements of this subdivision can not be met at the time of completion of installation, the owner shall have a period of thirty (30) days to comply with the above requirements; provided, however, that during said thirty (30) day period, a battery operated carbon monoxide detector with an alarm shall be installed.

Approved Carbon Monoxide Detectors

Each carbon monoxide detector as required in accordance with the above provisions shall comply with NFPA 720 and ANSI/UL 2034 listed and IAS certified.

Signage

A metal or plastic identification plate shall be permanently mounted to the exterior of the building at a minimum height of eight (8) feet above grade directly in line with the exhaust vent terminal for the horizontally vented gas fueled heating appliance or equipment. The sign shall read, in print size no less than one-half (1/2) inch in size, "**GAS VENT DIRECTLY BELOW, KEEP CLEAR OF ALL OBSTRUCTIONS**".

Inspection

The state or local gas inspector of the side wall horizontally vented gas fueled equipment shall not approve the installation unless, upon inspection, the inspector observes carbon monoxide detectors and signage installed in accordance with the provisions of 248 CMR 5.08(2)(a)1 through 4.

Exemptions

The following equipment is exempt from 248 CMR 5.08(2)(a)1 through 4:

- The equipment listed in Chapter 10 entitled "Equipment Not Required To Be Vented" in the most current edition of NFPA 54 as adopted by the Board; and
- Product Approved side wall horizontally vented gas fueled equipment installed in a room or structure separate from the dwelling, building or structure used in whole or in part for residential purposes.

MANUFACTURER REQUIREMENTS

Gas Equipment Venting System Provided

When the manufacturer of Product Approved side wall horizontally vented gas equipment provides a venting system design or venting system components with the equipment, the instructions provided by the manufacturer for installation of the equipment and the venting system shall include:

- Detailed instructions for the installation of the venting system design or the venting system components; and
- A complete parts list for the venting system design or venting system.

Gas Equipment Venting System NOT Provided

When the manufacturer of a Product Approved side wall horizontally vented gas fueled equipment does not provide the parts for venting the flue gases, but identifies "special venting systems", the following requirements shall be satisfied by the manufacturer:

- The referenced "special venting system" instructions shall be included with the appliance or equipment installation instructions; and
- The "special venting systems" shall be Product Approved by the Board, and the instructions for that system shall include a parts list and detailed installation instructions.

A copy of all installation instructions for all Product Approved side wall horizontally vented gas fueled equipment, all venting instructions, all parts lists for venting instructions, and/or all venting design instructions shall remain with the appliance or equipment at the completion of the installation.

Fireplace Dimensions

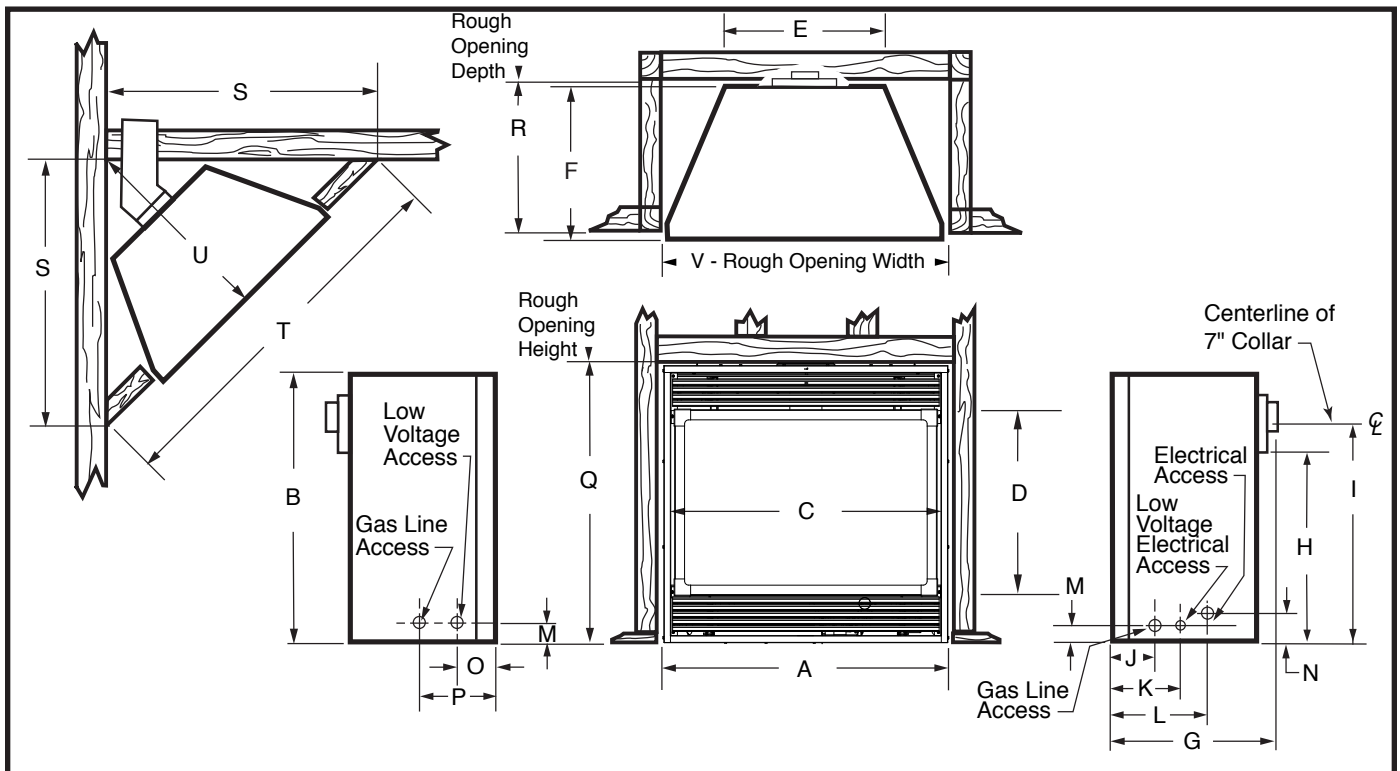

Fig. 1 Fireplace specifications and framing dimensions.

| Ref. | 33LDVR | 36LDVR | 39LDVR | 43LDVR |
|---------------------------|---|--|--|--|
| A | 33" (838 mm) | 36" (914 mm) | 39" (991 mm) | 43" (1092 mm) |
| B | 28 ⁷ / ₈ " (733 mm) | 34 ¹ / ₄ " (870 mm) | 34 ¹ / ₄ " (870 mm) | 37" (940 mm) |
| C | 31 ¹ / ₄ " (794 mm) | 34 ¹ / ₄ " (870 mm) | 37 ¹ / ₄ " (946 mm) | 41 ¹ / ₄ " (1048 mm) |
| D | 18 ³ / ₈ " (466 mm) | 23" (584 mm) | 23" (584 mm) | 25 ³ / ₄ " (654 mm) |
| E | 24 ⁷ / ₈ " (632 mm) | 24" (610 mm) | 27" (686 mm) | 31" (788 mm) |
| F | 11 ¹ / ₂ " (292 mm) | 16" (406 mm) | 16" (406 mm) | 16" (406 mm) |
| G | 14 ¹ / ₄ " (362 mm) | 18 ³ / ₄ " (476 mm) | 18 ³ / ₄ " (476 mm) | 18 ³ / ₄ " (476 mm) |
| H | 19 ³ / ₄ " (501 mm) | 24 ¹ / ₄ " (616 mm) | 24 ¹ / ₄ " (616 mm) | 27" (686 mm) |
| I | 23 ¹ / ₄ " (590 mm) | 27 ³ / ₄ " (705 mm) | 27 ³ / ₄ " (705 mm) | 30 ¹ / ₂ " (775 mm) |
| J | 4 ³ / ₄ " (121 mm) | 5 ⁵ / ₈ " (143 mm) | 5 ⁵ / ₈ " (143 mm) | 5 ⁵ / ₈ " (143 mm) |
| K | 6 ⁵ / ₁₆ " (160 mm) | 8" (203 mm) | 8" (203 mm) | 8" (203 mm) |
| L | 8 ⁷ / ₈ " (225 mm) | 11 ⁷ / ₈ " (302 mm) | 11 ⁷ / ₈ " (302 mm) | 11 ⁷ / ₈ " (302 mm) |
| M | 2" (51 mm) | 2" (51 mm) | 2" (51 mm) | 2" (51 mm) |
| N | 3 ³ / ₈ " (86 mm) | 3 ¹ / ₄ " (83 mm) | 3 ¹ / ₄ " (83 mm) | 3 ¹ / ₄ " (83 mm) |
| O | 4 ³ / ₄ " (121 mm) | 6 ³ / ₄ " (172 mm) | 6 ³ / ₄ " (172 mm) | 6 ³ / ₄ " (172 mm) |
| P | 6 ⁵ / ₁₆ " (160 mm) | 9 ¹ / ₄ " (235 mm) | 9 ¹ / ₄ " (235 mm) | 9 ¹ / ₄ " (235 mm) |
| Framing Dimensions | | | | |
| Q | 29 ⁵ / ₈ " (753 mm) | 35" (889 mm) | 35" (889 mm) | 37 ³ / ₄ " (959 mm) |
| R | 12" (305 mm) | 16 ¹ / ₂ " (419 mm) | 16 ¹ / ₂ " (419 mm) | 16 ¹ / ₂ " (419 mm) |
| S | 36" (914 mm) | 41 ⁵ / ₈ " (1057 mm) | 44" (1118 mm) | 44 ¹ / ₈ " (1121 mm) |
| T | 51" (1295 mm) | 58 ⁷ / ₈ " (1495 mm) | 62 ¹ / ₄ " (1581 mm) | 62 ³ / ₈ " (1584 mm) |
| U | 25 ¹ / ₂ " (648 mm) | 29 ⁷ / ₈ " (748 mm) | 31 ¹ / ₈ " (790 mm) | 31 ¹ / ₄ " (794 mm) |
| V | 33 ¹ / ₂ " (851 mm) | 36 ¹ / ₂ " (927 mm) | 39 ¹ / ₂ " (1003 mm) | 43 ¹ / ₂ " (1105 mm) |

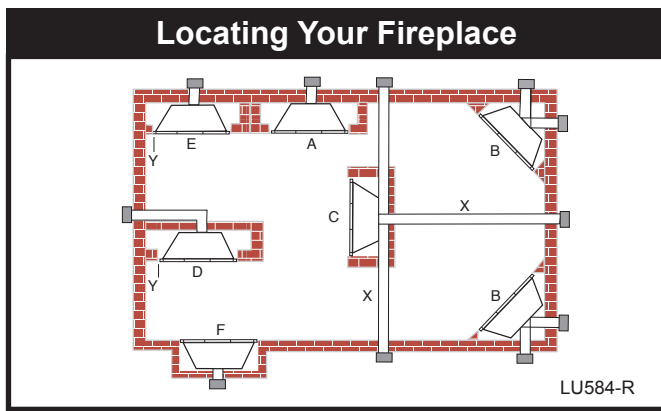

Fig. 2 Locate gas fireplace.

- A) Flat on wall B) Cross corner C) **Island
 D) *Room divider E) *Flat on wall corner F) Chase installation
 Y) 6" minimum

NOTE: (Fig. 2)

** Island (C) and Room Divider (D) installation is possible as long as the horizontal portion of the vent system (X) does not exceed 20' (610cm). See details in Venting Section.

* When you install your fireplace in (D) Room divider or (E) Flat on wall corner positions (Y), a minimum of 6" (153mm) clearance must be maintained from the perpendicular wall and the front side edge of the fireplace. Refer to (Y) in Figure 2.

Clearance to Combustibles

Top of Unit to Ceiling 36" (914 mm)

Appliance

- Top 0" (0 mm)
 Bottom 0" (0 mm)
 Side 0" (0 mm)
 Back 0" (0 mm)

Venting

Concentric sections of DV Vent

- Top, bottom & sides 1" (25 mm)

Rear Vent Applications:

- Top 2" (50 mm)
 Sides and Bottom 1" (25 mm)

Flex Vent 7/8" (22 mm)

Mantels

The height that a combustible mantel is fitted above the fireplace is dependent on the depth of the mantel. This also applies to the distance between the mantel leg (if fitted) and the fireplace.

For the correct mounting height and widths refer to Figs. 3a and 3b, and the following Mantel Charts.

The fitting of a bay window trim kit does not effect the distances and reference points referred to in the diagram and chart.

Noncombustible mantels and legs may be installed at any height and width around the appliance.

When using paint or lacquer to finish the mantel, such paint or lacquer must be heat resistant to prevent discoloration.

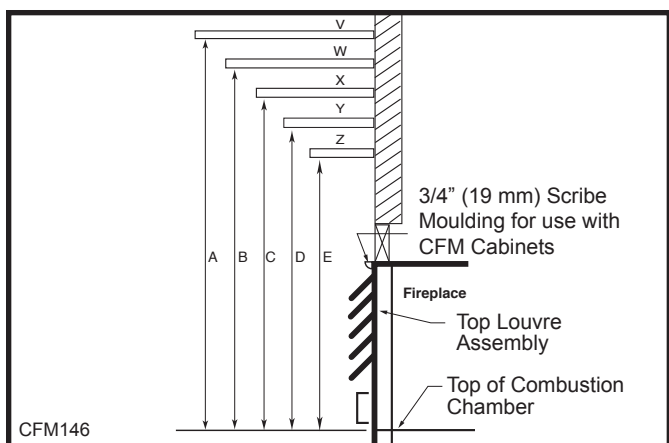

| Mantel Chart | | | | |
|--------------|------------------------------------|------|---------------------------------------|---------------|
| Ref. | Mantel Shelf or Breast Plate Depth | Ref. | Mantel from Top of Combustion Chamber | |
| | | | 36/39/43 LDVR | 33LDVR |
| V | 10" (254 mm) | A | 17" (432 mm) | 16½" (419 mm) |
| W | 8" (203 mm) | B | 15" (381 mm) | 14½" (368 mm) |
| X | 6" (152 mm) | C | 13" (330 mm) | 12½" (318 mm) |
| Y | 4" (102 mm) | D | 11" (279 mm) | 10½" (267 mm) |
| Z | 2" (51 mm) | E | 9" (229 mm) | 8½" (216 mm) |

Fig. 3a Combustible mantel minimum installation.

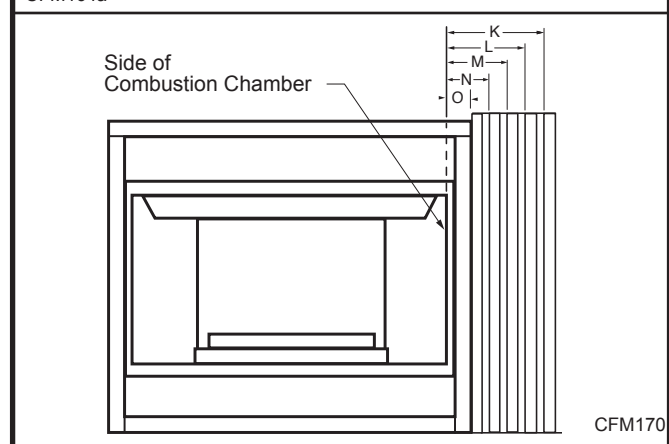
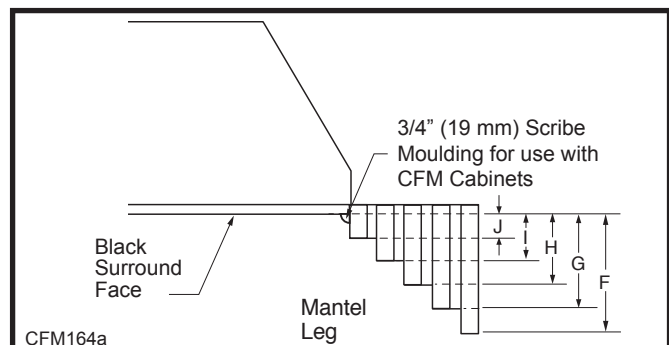

| Ref. | Mantel Leg Depth | Ref. | Mantel Leg From Side of Comb. Opening |
|------|------------------|------|---------------------------------------|
| F | 10" (254 mm) | K | 11½" (292 mm) |
| G | 8" (203 mm) | L | 9½" (241 mm) |
| H | 6" (152 mm) | M | 7½" (191 mm) |
| I | 4" (102 mm) | N | 5½" (140 mm) |
| J | 2" (51 mm) | O | 3½" (89 mm) |

Fig. 3b Combustible mantel leg minimum installation.

Hearth

A hearth is not mandatory but is recommended for aesthetic purposes. We recommend a noncombustible hearth which projects out 12" (305mm) or more from the front of the fireplace.

Cold climate installation recommendation:



When installing this unit against a non-insulated exterior wall or chase, it is mandatory that the outer walls be insulated to conform to applicable insulation codes.

Framing and Finishing



Check fireplace to make sure it is levelled and properly positioned.

To mount the appliance:

1. Choose the location.
2. This unit comes with four (4) flanges pre-mounted on both sides of the fireplace to allow two different drywall thicknesses to be used. Flange "A" is for 1/2" drywall while flange "B" is for 5/8" drywall.
3. Bend the desired flanges out 90° on both sides of the fireplace. Slide the fireplace into the framed opening until the flanges contact the front surfaces of the framing. Level the unit and secure it firmly in place.

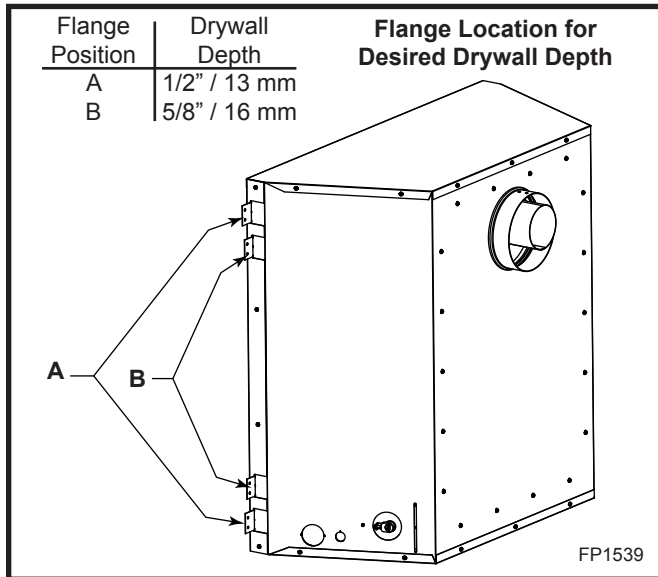

Fig. 4 Nailing flanges.

Final Finishing

Noncombustible materials such as brick or tile may be extended over the edges of the face of the fireplace. **DO NOT** cover any vent or grille panels.

If a Trim Kit is going to be installed on the fireplace, the brick or tile will have to be installed flush with the edges of the fireplace.

Gas Specifications

| Model | Fuel | Gas Control | Max. Input BTU/h | Min. Input BTU/h | Air Shutter Adj. |
|----------|-------|-------------|------------------|------------------|-------------------------------|
| 33LDVRRN | Nat | Millivolt | 16,000 | 11,200 | 3/16" Open |
| 33LDVRRP | Prop | Millivolt | 16,000 | 12,000 | Fully Open |
| 33LDVREN | Nat | 24V Hi/Lo | 16,000 | 11,200 | 3/16" Open |
| 33LDVREP | Prop* | 24V Hi/Lo | 16,000 | 12,000 | Fully Open |
| 36LDVRRN | Nat | Millivolt | 19,500 | 13,650 | Top & Bottom Hole Half Closed |
| 36LDVRRP | Prop | Millivolt | 19,500 | 14,625 | Fully Open |
| 36LDVREN | Nat | 24V Hi/Lo | 19,500 | 13,650 | Top & Bottom Hole Half Closed |
| 36LDVREP | Prop* | 24V Hi/Lo | 19,500 | 14,625 | Fully Open |
| 39LDVRRN | Nat | Millivolt | 23,000 | 16,100 | Top & Bottom Hole Half Closed |
| 39LDVRRP | Prop* | Millivolt | 22,500 | 16,875 | Fully Open |
| 39LDVREN | Nat | 24V Hi/Lo | 23,000 | 16,100 | Top & Bottom Hole Half Closed |
| 39LDVREP | Prop* | 24V | 22,500 | 16,875 | Fully Open |
| 43LDVRRN | Nat | Millivolt | 26,000 | 18,200 | Top & Bottom Hole Half Closed |
| 43LDVRRP | Prop* | Millivolt | 24,000 | 18,000 | Fully Open |
| 43LDVREN | Nat | 24V Hi/Lo | 26,000 | 18,200 | Top & Bottom Hole Half Closed |
| 43LDVREP | Prop* | 24V Hi/Lo | 24,000 | 18,000 | Fully Open |

*Using conversion kit

Gas Inlet and Manifold Pressures

| | Natural | LP (Propane) |
|-------------------|------------|--------------|
| Inlet Minimum | 5.5" w.c. | 11.0" w.c. |
| Inlet Maximum | 14.0" w.c. | 14.0" w.c. |
| Manifold Pressure | 3.5" w.c. | 10.0" w.c. |

High Elevations

Input ratings are shown in BTU per hour and are certified without deration for elevations up to 4,500 feet (1,370m) above sea level.

For elevations above 4,500 feet (1,370m) in USA, installations must be in accordance with the current ANSI Z223.1/NFPA 54 and/or local codes having jurisdiction.

In Canada, please consult provincial and/or local authorities having jurisdiction for installations at elevations above 4,500 feet (1,370m).

Gas Line Installation



When purging the gas lines, the front window frame assembly must be removed.

The gas pipeline can be brought in through the rear of the appliance as well as the bottom. Knockouts are provided on the bottom behind the valve to allow for the gas pipe installation and testing of any gas connection. It is most convenient to bring the gas line in from the rear right side of the valve as this allows fan installation or removal without disconnecting the gas line.

The gas line connection can be made with properly tinned 3/8" copper tubing, 3/8" rigid pipe or an approved flex connector. Since some municipalities have additional local codes, it is always best to consult your local authority and the National Fuel Gas Code, ANSI Z223.1/NFPA 54 in the USA or the CSA-B149.1 installation code.

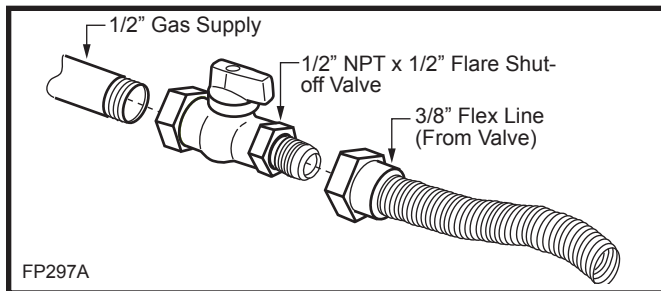

Fig. 5 Typical gas supply installation.



Always check for gas leaks with a mild soap and water solution. Do not use an open flame for leak testing.

The gas control is equipped with a captured screw type pressure test point, therefore it is not necessary to provide a 1/8" test point up stream of the control.

When using copper or flex connector use only approved fittings. Always provide a union when using black iron pipe so the gas line can be easily disconnected for burner or fan servicing. See gas specification for pressure details and ratings.

The fireplace valve must not be subjected to any test pressures exceeding 1/2 psi. Isolate or disconnect this and any other gas appliance control from the gas line when pressure testing.

Remote ON/OFF Switch

Installation

1. Thread the wiring through the holes on the end panels of the fireplace. Take care not to cut the wire or insulation on metal edges. Route the wire to a conveniently located receptacle box.
2. Attach the wire to the ON/OFF switch and install the switch into the receptacle box.
3. Connect the other ends of the wire to the gas control valve. (Fig. 6)

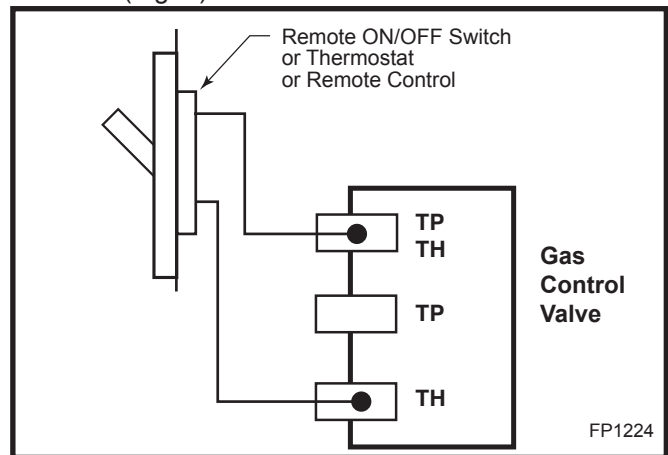

Fig. 6 Remote switch wiring diagram.

Alternate Switch Location

The remote switch can be installed on the front/side of the access door. Simply mount the switch to the bracket provided and screw the bracket to either side of the frame, lining up the screws with the pre-punched holes. (Fig. 7)

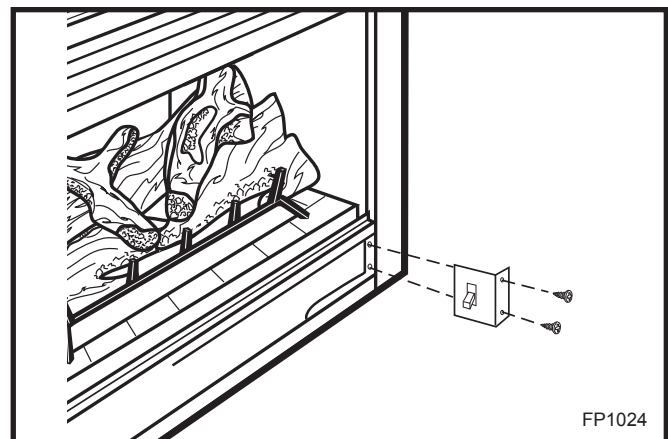

Fig. 7 Alternate switch location.



Do not wire the remote ON/OFF wall switch for the gas fireplace to the 120 volt power supply.

EB-1 Electrical Box



The fireplace, when installed, must be electrically connected and grounded in accordance with local codes or, in the absence of local codes, with the current CSA C22.1 Canadian Electrical Code.



For USA installations follow local codes and the national electrical code ANSI/NFPA No. 70.



It is strongly suggested that the wiring of the EB-1 Electrical Junction Box be carried out by a licensed electrician.



Ensure that the power to the supply line has been disconnected before commencing this procedure.

The EB-1 Electrical junction box has been fitted standard on this model to allow for the easy connection of an optional fan kit.

To connect the EB-1 box to the house electrical supply follow the steps below.

1. Unscrew the retaining screw from the EB-1 base plate and remove the EB-1 assembly from the appliance. (Fig. 8)
2. Remove the front cover of the EB-1 box.
3. Remove the plug socket assembly from the EB-1 box.
4. Feed the supply line in through the EB-1 opening in the side of the appliance and then through the back of the EB-1 assembly. (Fig. 8)
5. Connect the black wire of the power supply line to the brass screw (polarized) of the socket assembly.
6. Connect the white wire of the power line to the chrome screw of the socket assembly.
7. Connect the ground wire of the supply line to the green screw of the socket assembly.
8. Refit the socket assembly back into the electrical box and replace the cover plate. Secure the cable with the clamp on the outside of the EB-1 base plate and refit the EB-1 assembly to the unit with the screw removed in step 1.

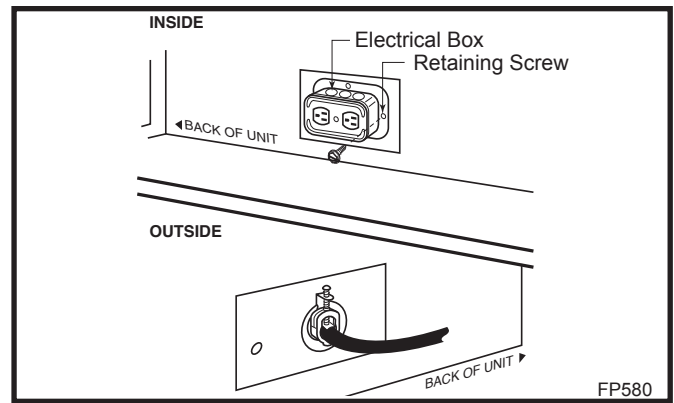

Fig. 8 EB-1 receptacle.

Electronic Gas Control Valve

This appliance may be fitted with a Synetek ignition module.

Installation of the remote on/off starter switch or wall thermostat on electronic ignition units.

1. Thread the wiring through the holes on the side panels of the appliance. Take care not to cut the wire or insulation on metal edges. Route the wire to a conveniently located receptacle box.
2. Attach the wire to the ON/OFF switch and install the switch into the receptacle box.
3. Connect the white wire from the wall switch or wall thermostat to the white wire terminal from the electronic module. Connect the black wire from the wall switch or the red wire from the wall thermostat, to the red wire terminal from the electronic module.

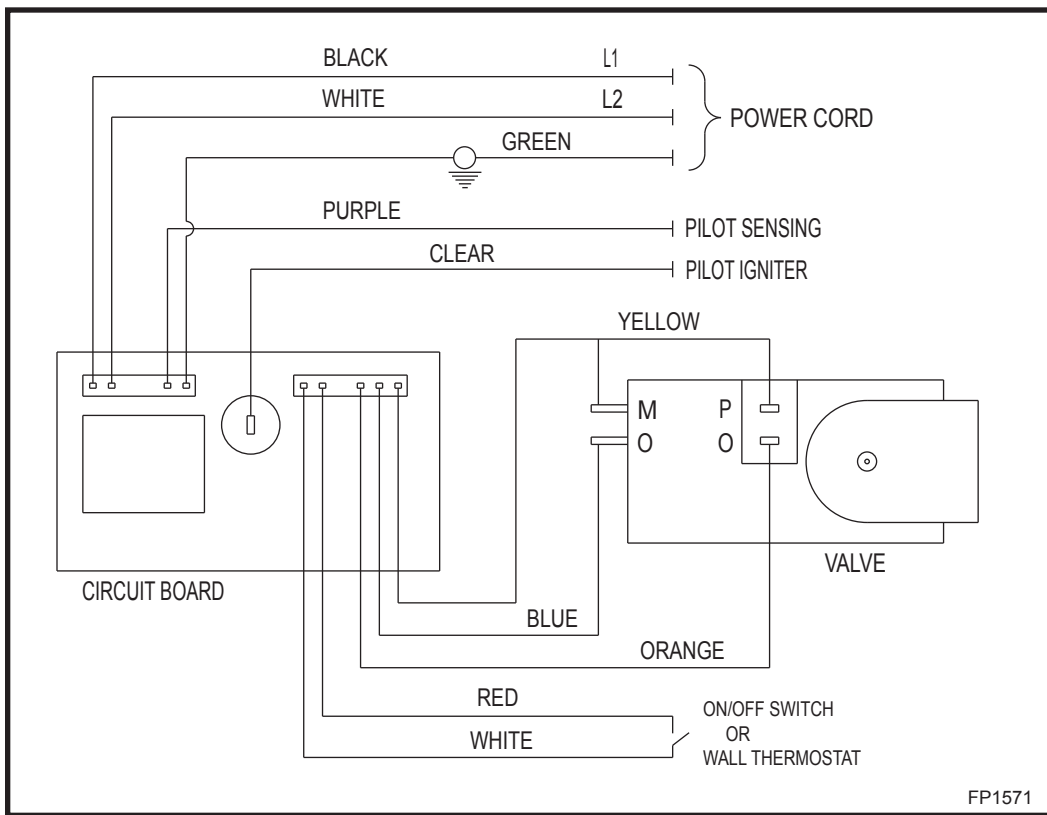

Fig. 9 SIT822 Valve with Synetek electronic control wiring diagram.

General Venting

Your fireplace is approved to be vented either through the side wall, or vertically through the roof.

- Only CFM Corporation venting components specifically approved and labelled for this fireplace may be used.
- Vent terminations shall not be recessed into a wall or siding.
- Horizontal venting which incorporates the twist lock pipe must be installed on a level plane without an inclining or declining slope.
- Horizontal venting which incorporates the use of flex venting shall have an inclining slope from the unit of 1" (25 mm) per 24" (610 mm).

There must not be any obstruction such as bushes, garden sheds, fences, decks or utility buildings within 24" (610mm) from the front of the termination hood.

Do not locate termination hood where excessive snow or ice build up may occur. Be sure to check vent termination area after snow falls, and clear to prevent accidental blockage of venting system. When using snow blowers, make sure snow is not directed towards vent termination area.

Location of Vent Termination

It is imperative the vent termination be located observing the minimum clearances as shown on the next page.

*Check with local codes or in absence of same with CSAB149.1 Installation Codes (1991) for Canada or follow the current National Fuel Gas Code, ANSI Z223.1/ NFPA 54 for installations in the USA.

General Venting Information - Termination Location

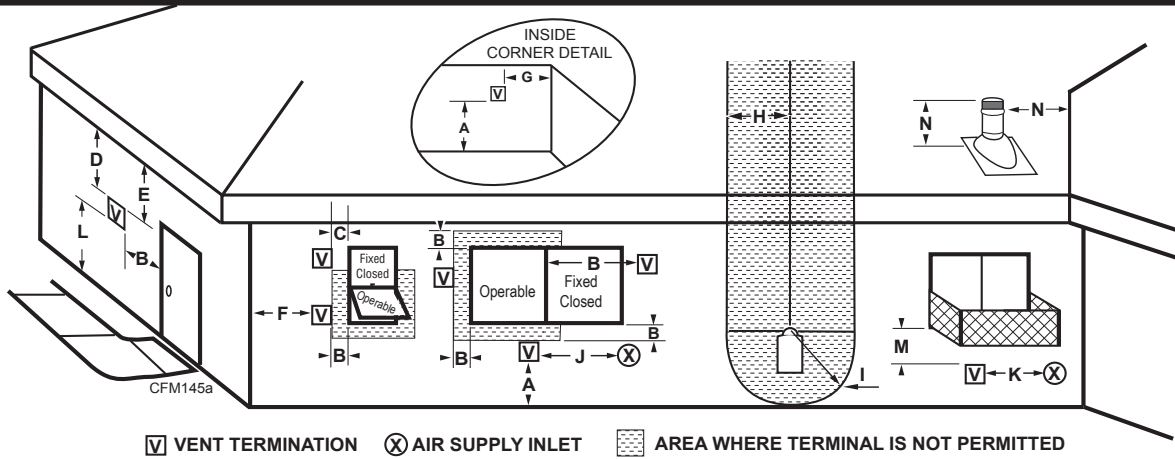

| | Canadian Installations ¹ | US Installations ² |
|--|--|---|
| A = Clearance above grade, veranda, porch, deck, or balcony | 12" (30cm) | 12" (30cm) |
| B = Clearance to window or door that may be opened | 6" (15cm) for appliances < 10,000 Btuh (3kW), 12" (30cm) for appliances > 10,000 Btuh (3kW) and < 100,000 Btuh (30kW), 36" (91cm) for appliances > 100,000 Btuh (30kW) | 6" (15cm) for appliances < 10,000 Btuh (3kW), 9" (23cm) for appliances > 10,000 Btuh (3kW) and < 50,000 Btuh (15kW), 12" (30cm) for appliances > 50,000 Btuh (15kW) |
| C = Clearance to permanently closed window | 12" (305mm) recommended to prevent window condensation | 12" (305mm) recommended to prevent window condensation |
| D = Vertical clearance to ventilated soffit located above the terminal within a horizontal distance of 2' (610mm) from the center line of the terminal | 18" (458mm) | 18" (458mm) |
| E = Clearance to unventilated soffit | 12" (305mm) | 12" (305mm) |
| F = Clearance to outside corner | see next page | see next page |
| G = Clearance to inside corner (see next page) | see next page | see next page |
| H = Clearance to each inside of center line extended above meter/regulator assembly | 3' (91cm) within a height of 15' (5m) above the meter/regulator assembly | 3' (91cm) within a height of 15' (5m) above the meter/regulator assy |
| I = Clearance to service regulator vent outlet | 3' (91cm) | 3' (91cm) |
| J = Clearance to nonmechanical air supply inlet to building or the combustion air inlet to any other appliances | 6" (15cm) for appliances < 10,000 Btuh (3kW), 12" (30cm) for appliances > 10,000 Btuh (3kW) and < 100,000 Btuh (30kW), 36" (91cm) for appliances > 100,000 Btuh (30kW) | 6" (15cm) for appliances < 10,000 Btuh (3kW), 9" (23cm) for appliances > 10,000 Btuh (3kW) and < 50,000 Btuh (15kW), 12" (30cm) for appliances > 50,000 Btuh (15kW) |
| K = Clearance to a mechanical air supply inlet | 6' (1.83m) | 3' (91cm) above if within 10 feet (3m) horizontally |
| L = Clearance above paved sidewalk or paved driveway located on public property | 7' (2.13m)† | 7' (2.13m)† |
| M = Clearance under veranda, porch, deck or balcony | 12" (30cm)‡ | 12" (30cm)‡ |
| N = Clearance above a roof shall extend a minimum of 24" (610mm) above the highest point when it passes through the roof surface, and any other obstruction within a horizontal distance of 18" (450mm). | | |

1 In accordance with the current CSA-B149 Installation Codes
 2 In accordance with the current ANSI Z223.1/NFPA 54 National Fuel Gas Codes
 † A vent shall not terminate directly above a sidewalk or paved driveway which is located between two single family dwellings and serves both dwellings
 ‡ only permitted if veranda, porch, deck or balcony is fully open on a minimum 2 sides beneath the floor:
 NOTE: 1. Local codes or regulations may require different clearances.
 2. The special venting system used on Direct Vent Fireplaces are certified as part of the appliance, with clearances tested and approved by the listing agency.
 3. CFM Corporation assumes no responsibility for the improper performance of the appliance when the venting system does not meet these requirements.

Fig. 10 Vent termination locations.

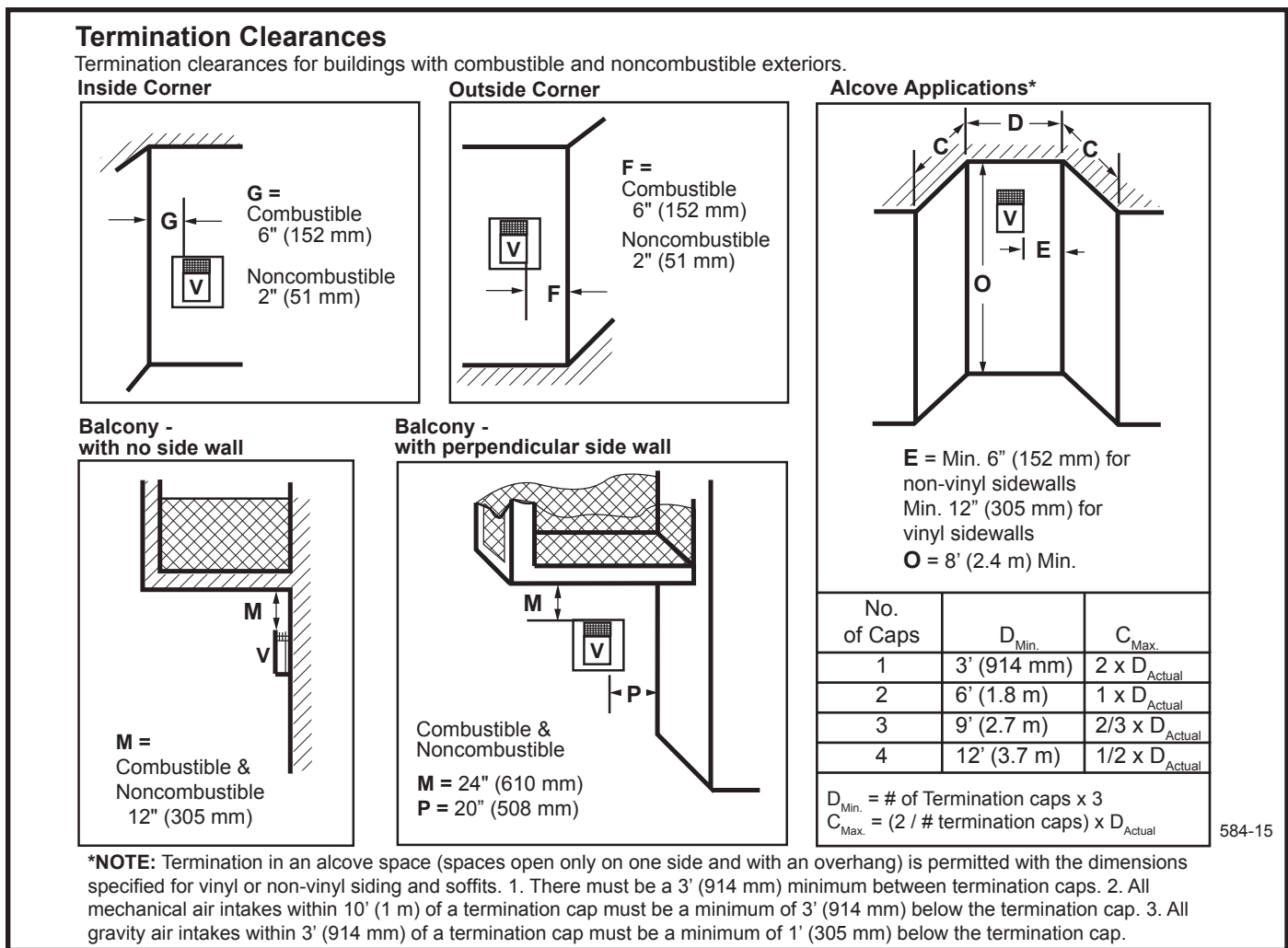

Fig. 10a Termination clearances.

General Information Assembling Vent Pipes

Canadian Installations:

Venting system must be installed in accordance with the current CSA-B149.1 installation code.

USA Installations:

The venting system must conform with local codes and/or the current National Fuel Gas code ANSI Z223.1/ NFPA 54.

Only venting components manufactured by CFM Corporation can be used in Direct Vent systems.

Flex Vent Pipes

Before joining the flex vent pipe to the unit, apply a bead of high temperature sealant* (provided) to the 4" pipe exiting the fireplace. Secure flex vent pipe in place with a hose clamp (provided).

*Be sure the flex pipe overlaps at least 1" (25mm) onto the collars of the fireplace and termination. If the termination has an internal bead, be sure to overlap and secure 1" (25mm) past the bead.

* Be sure the vent is actually crushed before proceeding. Apply a tug to be sure the vent will not slip off the collars.

Repeat process with 7" flex vent pipe. The same procedure must be performed on the vent side.

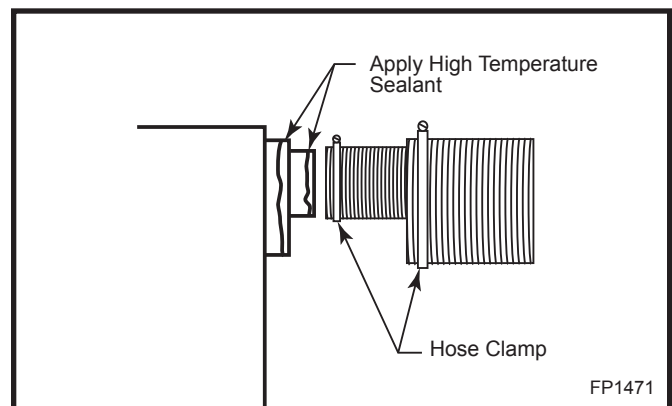

Fig. 11 Apply high temperature sealant to 4" and 7" pipes.

Twist Lock Pipes

When using CFM Corporation twist-lock pipe it is not necessary to use sealant on the joints. The only areas of the venting system that need to be sealed with high temperature silicone sealant are the sliding joints of any telescopic vent section used in the system.

To join the twist lock pipes together, simply align the beads of the male end with the grooves of the female end, then while bringing the pipe together, twist the pipe until the flange on the female end contacts the external flange on the male end. It is recommended that you secure the joints with three (3) sheet metal screws, however this is not mandatory with twist lock pipe.

To make it easier to assemble the joints we suggest putting a lubricant (Vaseline or similar) on the male end of the twist lock pipe prior to assembly.

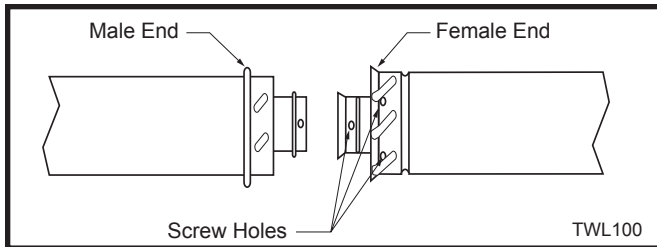

Fig. 12 Twist-lock pipe joints.

How to Use the Vent Graph

The vent chart should be read in conjunction with the following vent installation instructions to determine the relationship of the vertical and horizontal dimensions of the vent system.

1. Determine the height of the center of the horizontal vent pipe exiting through the outer wall. Using this dimension on the Sidewall Vent Graph (Fig. 13) locate the point intersecting with slanted graph line.
2. From the point of this intersection, draw a vertical line to the bottom of the graph.
3. Select the indicated dimension, and position the fireplace in accordance with same.

Example A:

If the vertical dimension from the floor of the fireplace is 11' (3.4 m) the horizontal run to the face of the outer wall must not exceed 14' (4.3 m).

Example B:

If the vertical dimension from the floor of the unit is 7' (2.14 m), the horizontal run to the face of the outer wall must not exceed 8½' (2.6 m).

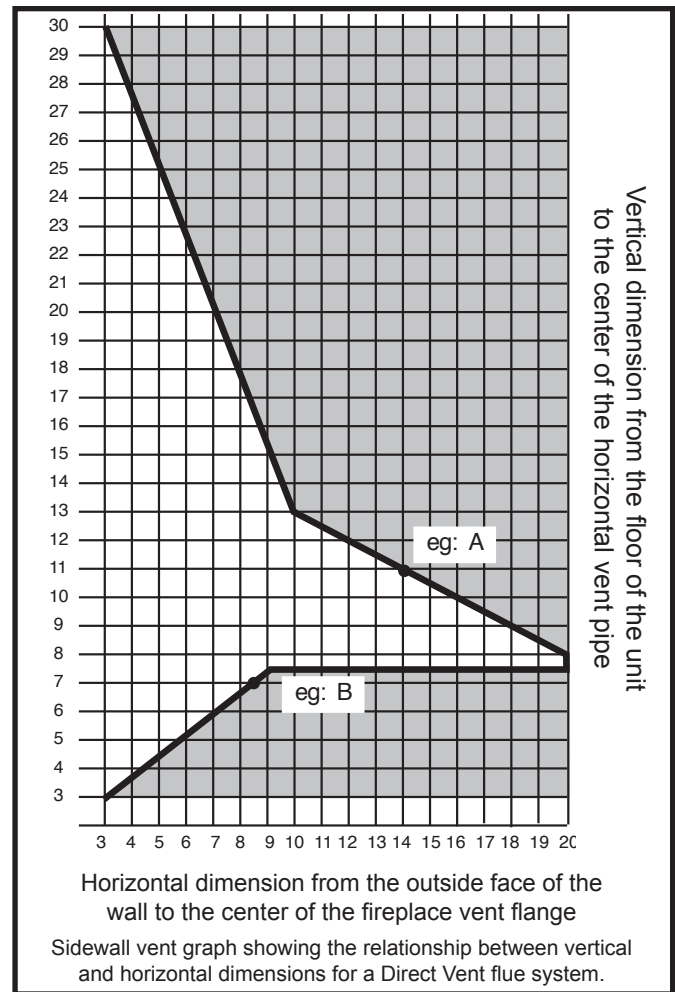

Fig. 13 Sidewall venting graph. (Dimensions in feet)

Rear Wall Venting Applications

When installed as a rear vent unit this appliance may be vented directly to a termination located on the rear wall behind the appliance.

- Only CFM Corporation venting components are approved to be used in these applications. (Refer to "Venting Components" listed for different installation requirements)
- The maximum horizontal distance between the rear of the appliance (or end of the transition elbow in a corner application) and the outside face of the rear wall is 20" (508mm). (Fig. 14)
- Only one 45° elbow is allowed in these installations.
- Minimum clearances between vent pipe and combustible materials are as follows:
 - Top - 2" (51 mm)
 - Sides - 1" (25 mm)
 - Bottom - 1" (25 mm)

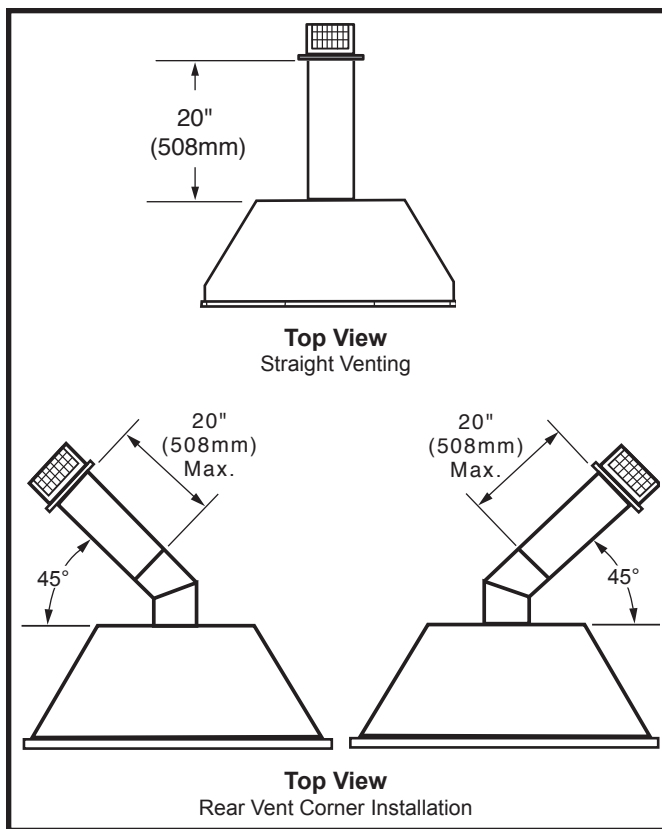

Fig. 14 Rear vent applications, one 45° elbow.

Rear Wall Installation Twist Lock Pipe

STEP 1

Locate vent opening on the wall. To locate hole center consult with appropriate fireplace dimensions, Page 4. Frame as shown below.

NOTE: When using flex vent, the opening will have to be measured according to the 1/2" (13 mm) rise in 12" (305 mm) vertical run.

Combustible Walls (Fig. 15): Cut a 10³/₈" H x 9³/₈" W (264 x 240 mm) hole through the exterior wall and frame as shown.

Noncombustible Walls (Fig. 15): Hole opening must be 7¹/₂" (190mm) in diameter.

STEP 2

Measure wall thickness and cut zero clearance sleeve parts to proper length (MAXIMUM 12"/305 mm). Assemble sleeve and attach to firestop with #8 sheet metal screws (supplied). (Fig. 16)

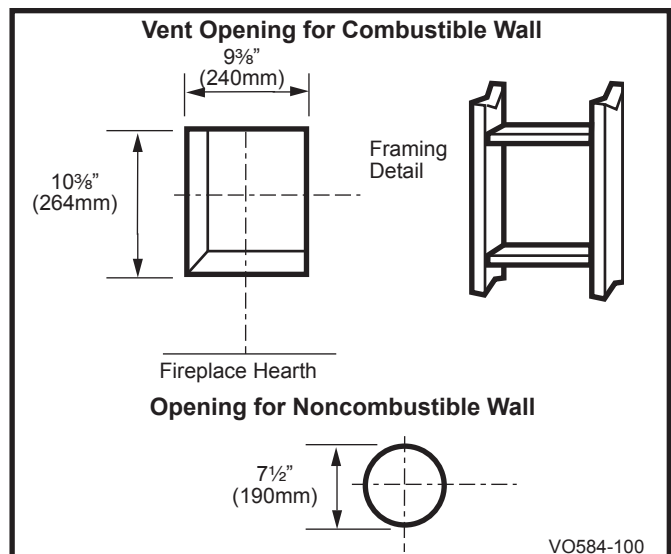

Fig. 15 Locate vent opening on wall.

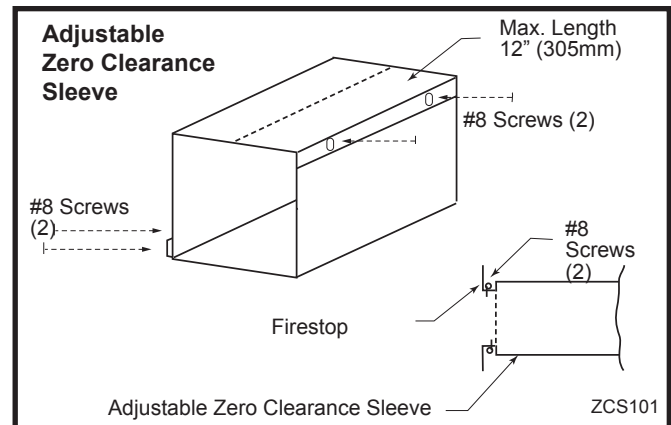

Fig. 16 Adjustable zero clearance sleeve.

STEP 3

Measure from the fireplace collar or elbow face to face of outside wall (add 2" for vent pipe overlap). Mark pipes and cut to length. It is very important that the two pipes are flush with the outside wall once the fireplace is in its final location. (Fig. 17)

STEP 4

Slip 4" and 7" pipes onto respective flue collars. Make sure to fix to the fireplace collar the 4" pipe with three (3) screws before fixing the 7" pipe on the 7" collar. Both pipes must be on a level plane. (Fig 18)

STEP 5

Guide the vent termination 4" collar into the 4" pipe then the 7" collar into the 7" pipe. Do not force the venting into position. If the pipes do not line up with the termination collars, disassemble pipes and reattach to the fireplace collar. (Fig. 18)

STEP 6

Secure fireplace to floor through floor holes and adjustable frame drywall strip (nailing flange) to frame. (Refer to Framing & Finishing Section).

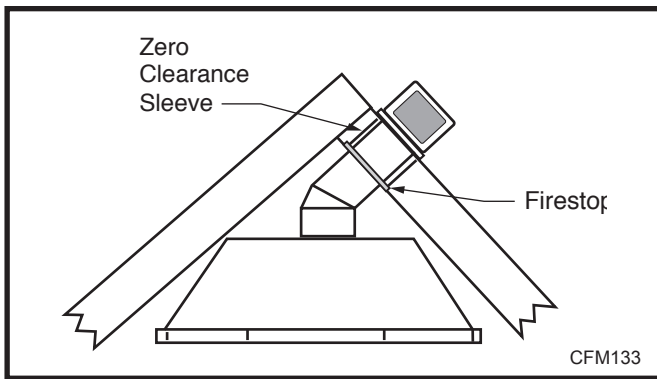

Fig. 17 Firestop and zero clearance sleeve in place.

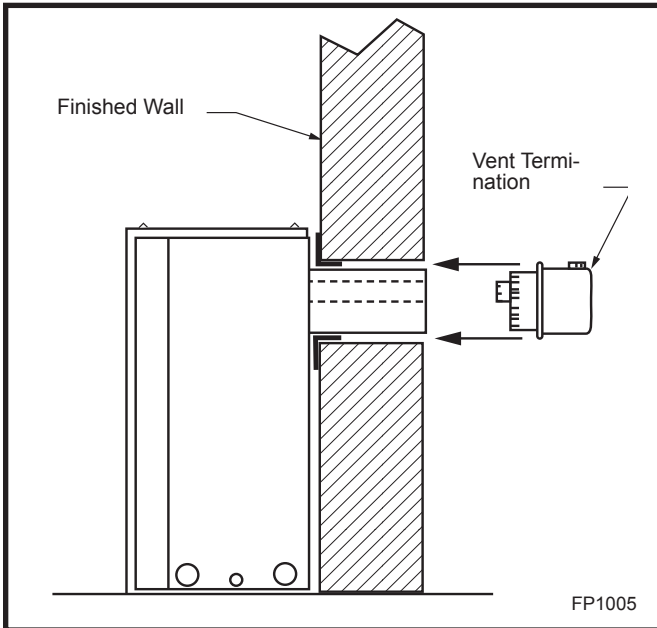

Fig. 18 Side view of final unit location.

Rear Wall Vent Installations - Flex Vent Pipe

Follow Steps 1 and 2 on Page 13.

Step 3

Install the 4" (102mm) flex vent pipe to the appliance collars described in "General Information Assembling Vent Pipes", Page 11. If the installation requires a 45° angle, grasp the vent pipe close to the appliance collar and bend to 45°. DO NOT exceed 45°. (Fig. 19) Install the 7" vent pipe in the same manner as Step 2.

NOTE: There must be a 1" (25 mm) rise in a 24" (610mm) length of flex vent.

Step 4

Assemble the flex vent to the collars on the termination as you did on the appliance.

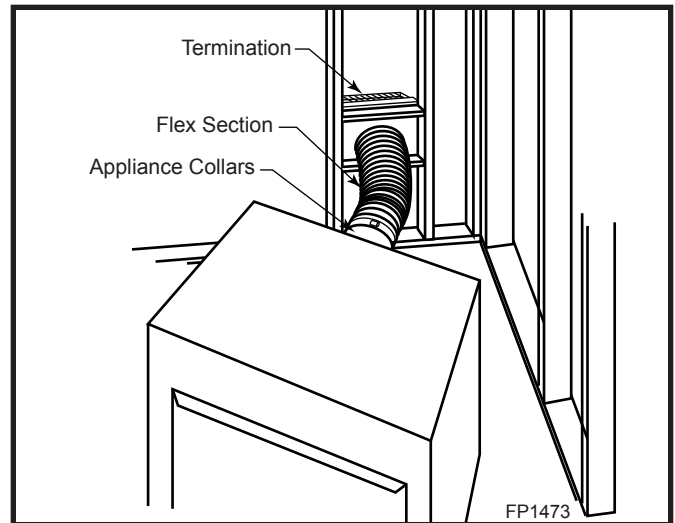

Fig. 19 Grasp the vent pipe close to the collar and bend to 45° angle. Do not exceed 45°.

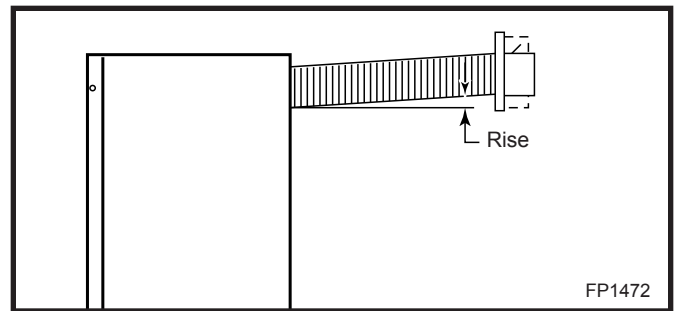

Fig. 20 There must be a 1/2" rise per foot length.

Vertical Sidewall Applications



Since it is very important that the venting system maintain its balance between the combustion air intake and the flue gas exhaust, certain limitations as to vent configurations apply and must be strictly adhered to.

The Vent Graph shows the relationship between vertical and horizontal side wall venting and will help to determine the various dimensions allowable.



Minimum clearance between vent pipes and combustibles is 1" (25 mm) on top, bottom and sides unless otherwise noted.

When vent termination exits through foundations less than 20" below siding outcrop, the vent pipe must flush up with the siding. It is always best to locate the fireplace in such a way that minimizes the number of offsets and horizontal vent length.

The horizontal vent run refers to the total length of vent pipe from the flue collar of the fireplace to the face of the outer wall.

Horizontal plane means no vertical rise exists on this portion of the vent assembly.

- The maximum horizontal vent run is 20 ft. (6.1 m) when the vertical vent rise is 7½ ft. (2.3 m). (Fig. 21)
- The maximum number of 90° elbows per side wall installation is three (3).

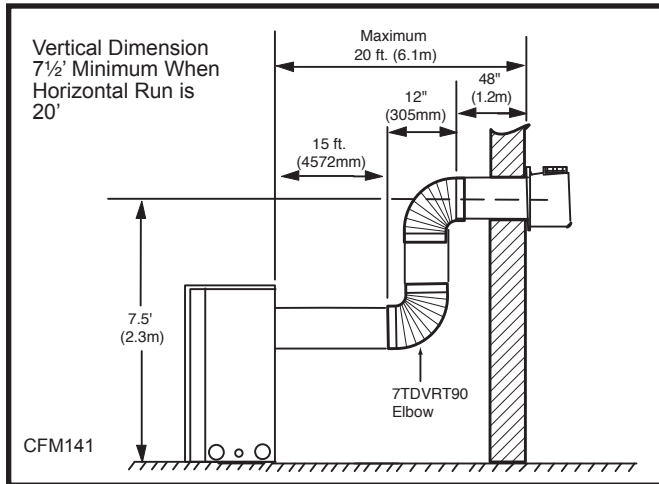

Fig. 21 Maximum number of 90° elbows is three (3).

- If a 90° elbow is used in the horizontal vent run (level height maintained) the maximum horizontal vent length is reduced by 36" (914 mm). (Fig. 22) This does not apply if the 90° elbows are used to increase or redirect a vertical rise. (Fig. 23)

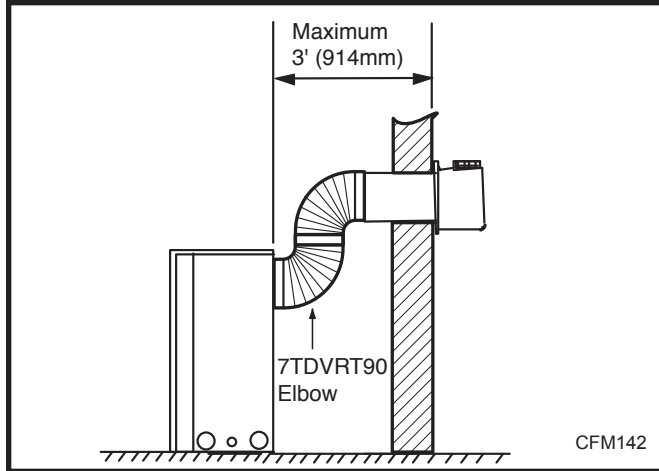

Fig. 22 Maximum horizontal vent run.

Example: According to the chart the maximum horizontal vent length in a system with a 7.5' (2.3 m) vertical rise is 20' (6 m) and if a 90° elbow is required in the horizontal vent it must be reduced to 17' (5.2 m). In Figure 23 Dimension A plus B must not be greater than 17' (5.2 m).

- The maximum number of 45° elbows permitted per side wall installation is two (2). These elbows can be installed in either the vertical or horizontal run.
- For each 45° elbow installed in the horizontal run, the length of the horizontal run MUST be reduced by

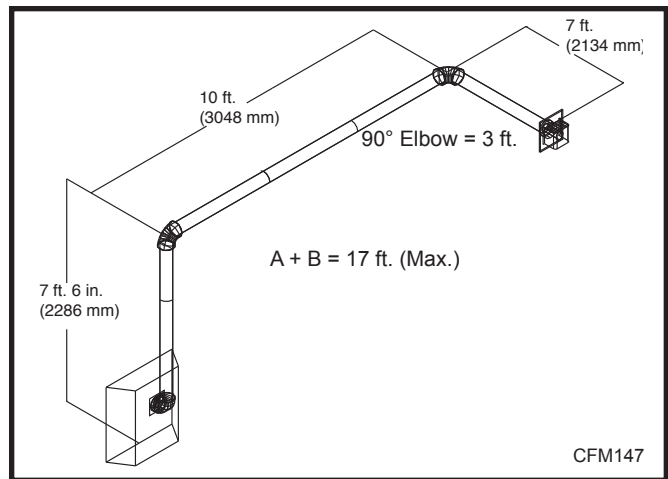

Fig. 23 Maximum vent run with elbows.

18" (45cm). This does not apply if the 45° elbows are installed on the vertical part of the vent system.

- The maximum number of elbow degrees in a system is 270°. (Fig. 24)

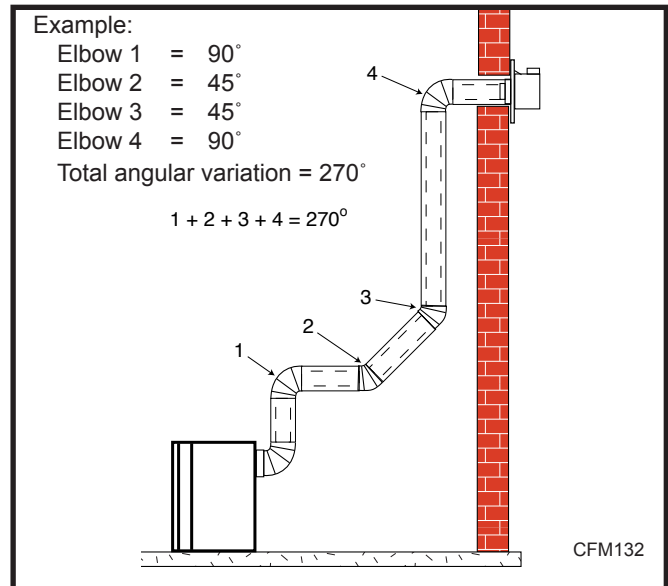

Fig. 24 Maximum number of elbows.

•**IMPORTANT**• Minimum clearance between vent pipes and combustible materials is one (1") inch (25 mm) on bottom, sides and top.



Twist Lock Vent Starter Kit 7TDVSK, plus Transition Elbow 7TDVRT90 must be used in Vertical Sidewall installations. The 4" pipe must be centered inside the 7" pipe coming off the transition elbow.

Canadian & USA Installations:

The venting system must conform with local codes, or in the absence of local codes, with National Fuel Gas Code, ANSI Z223.1/NFPA 54 - latest edition, or CSA B149.1 Installation Code.

Only CFM Corporation venting components specifically approved and labelled for this fireplace may be used.

Vertical Sidewall Installation

STEP 1

Locate vent opening on the wall. It may be necessary to first position the fireplace and measure to obtain hole location. Depending on whether the wall is combustible or noncombustible, cut opening to size. (Fig. 25)

For combustible walls first frame in opening.

Combustible Walls (Fig. 25): Cut a 9 $\frac{3}{8}$ " H x 9 $\frac{3}{8}$ " W (240 x 240 mm) hole through the exterior wall and frame.

Noncombustible Walls (Fig. 25): Hole opening must be 7.5" (190 mm) in diameter.

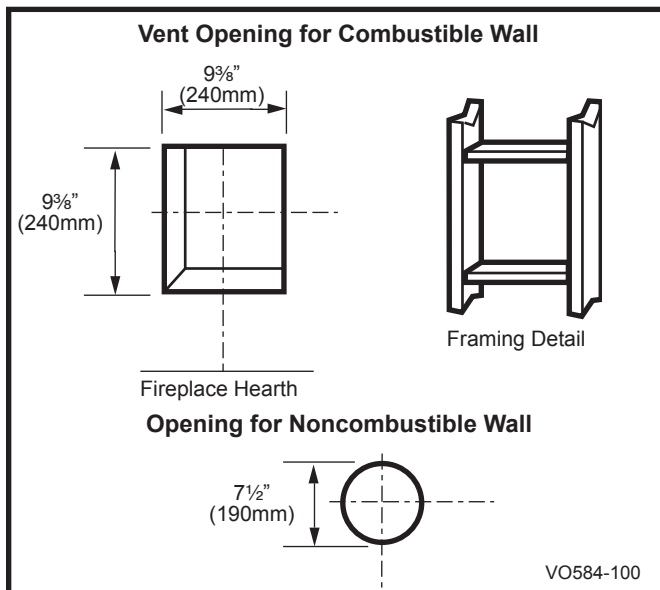

Fig. 25 Locate vent opening on wall.

STEP 2

Measure wall thickness and cut adjustable zero clearance sleeve parts to proper length (MAXIMUM 12"/305 mm). (Fig. 26) Adjust sleeve to minimum (9 $\frac{3}{8}$ " x 9 $\frac{3}{8}$ " and attach to firestop with #8 sheet metal screws (supplied). Assemble sleeve and attach to firestop with #8 sheet metal screws (supplied). Install firestop assembly.



Zero clearance sleeve is only required for combustible walls.

STEP 3

Attach the appropriate venting component(s) to the inner and outer flue collars of the fireplace using three (3) screws. (Fig. 27) Follow with the installation of the inner and outer elbow. Again secure joints with three (3) sheet metal screws.

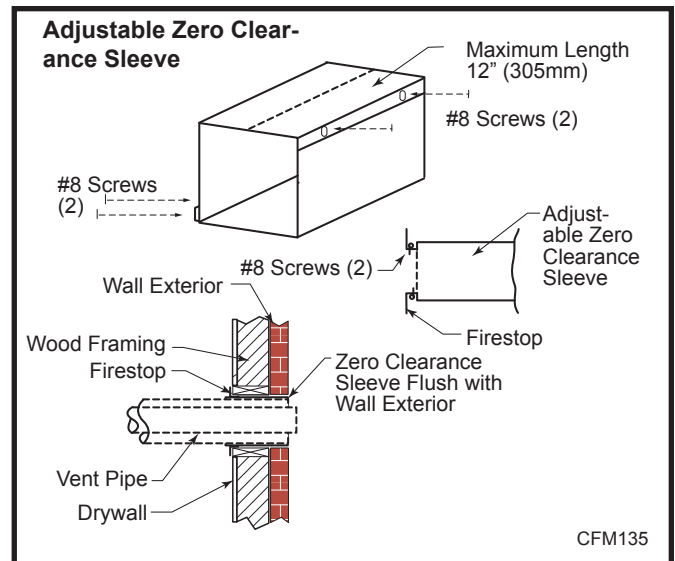

Fig. 26 Locate vent opening on wall.

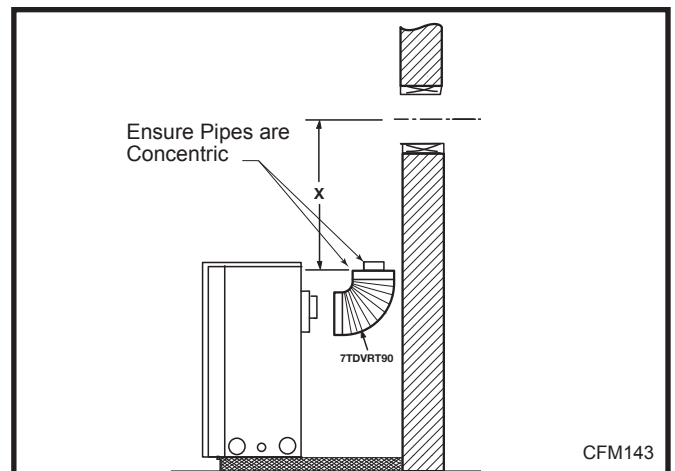

Fig. 27 Apply sealant to inner and outer pipe.

STEP 4

Measure the horizontal length requirement including a 2" (51 mm) overlap, i.e. from the elbow to the outside wall finish plus 2", or the distance required if installing a second 90° elbow. (Fig. 28)

STEP 5

Use appropriate length of pipe section - telescopic or fixed - and install the horizontal vent sections. The 20" (508 mm) section of pipe which goes through the wall is packaged with the 7TDVSK starter kit, and can be cut to suit if necessary. (Fig. 29)



Sealing vent pipe and firestop gaps with high temperature sealant will restrict cold air being drawn in around fireplace.

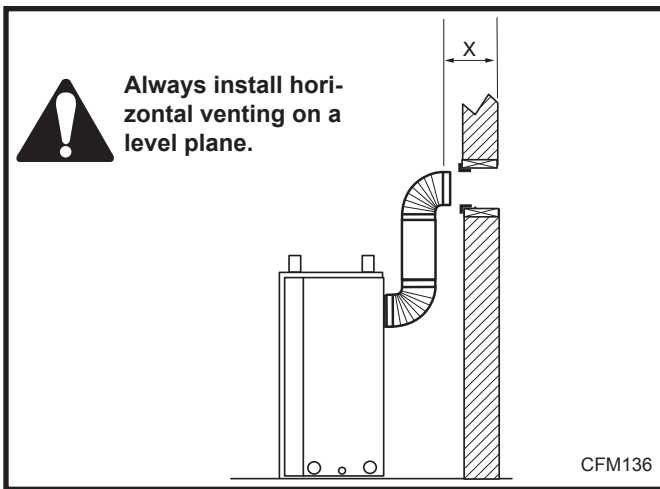

Fig. 28 Measure horizontal length including 2" overlap.

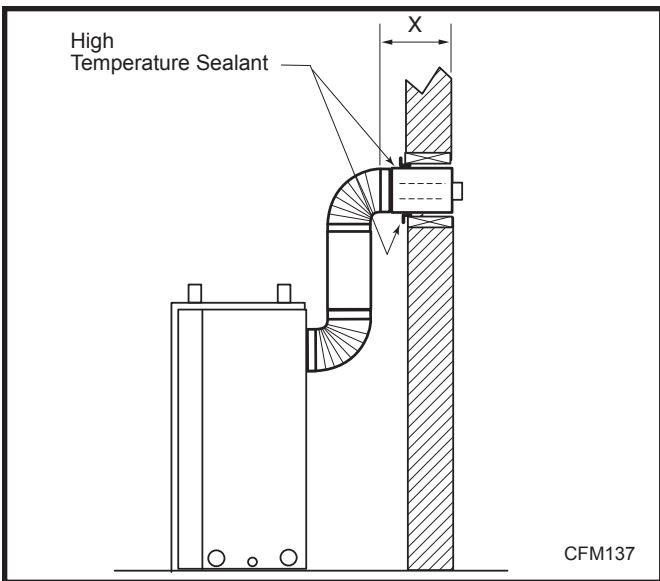

Fig. 29 Apply high temperature sealant.

STEP 6

Guide the vent termination's 4" (102 mm) and 7" (178 mm) collars into their respective vent pipes. Double check that the vent pipes overlap the collars by 2" (51 mm). Secure the termination to the wall with screws provided and caulk around the wall plate to weatherproof. (Fig. 30)

STEP 7

Support the horizontal pipes every 36" (914 mm) with metal pipe straps. Make sure that the horizontal vent pipe is installed on a level horizontal plane.

STEP 8

Re-check the fireplace to make sure that it is levelled, properly positioned, and nailed or screwed to the floor. If applied, the fireplaces adjustable frame drywall strips (nailing flanges) should be fastened. Refer to "Framing & Finishing".

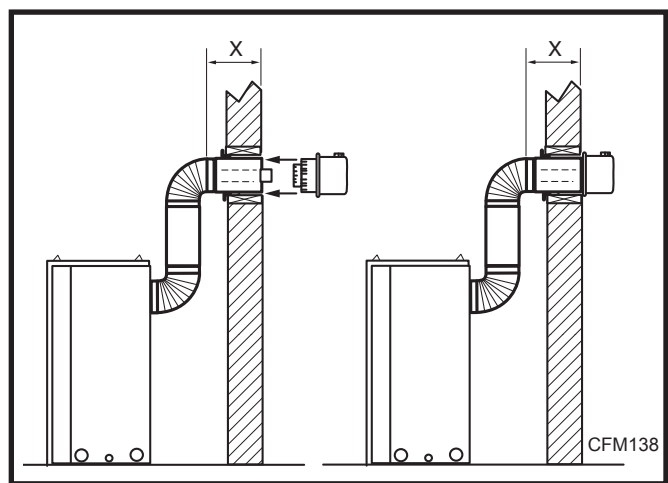

Fig. 30 Horizontal length requirement.

Below Grade Installations

When it is not possible to meet the required vent terminal clearances of 12" (305 mm) above grade level a snorkel vent kit #7TDVSNORK is required. It allows installation depth of down to 7" (178 mm) below grade level. The 7" is measured from the center of the horizontal vent pipe as it penetrates through the wall.



If venting system is installed below ground, we recommend a window well with adequate and proper drainage.

Ensure sidewall venting clearances are observed.



The maximum horizontal run with 24" vertical rise is 36" (914 mm) from the back of the fireplace to the face of the exterior wall. See vent graph (Page 12) for extended horizontal run if the vertical rise exceeds 24" (610 mm).

1. Establish vent hole through the wall. (Fig. 25)
2. Remove soil to a depth of approximately 16" (406mm) below base of snorkel. Install window well (not supplied). Refill hole with 12" (305 mm) of coarse gravel leaving a clearance of approximately 4" (102 mm) below snorkel. (Fig. 31)
3. Install vent system. See Page 13, Steps 2 through 5.
4. Ensure a watertight seal is made around the vent pipe coming through the wall.
5. Apply high temperature sealant caulking (supplied) around the 4" and 7" snorkel collars.
6. Slide into the vent pipe and secure to the wall.
7. Level the soil to maintain a 4" (102 mm) clearance below snorkel. (Fig. 31)

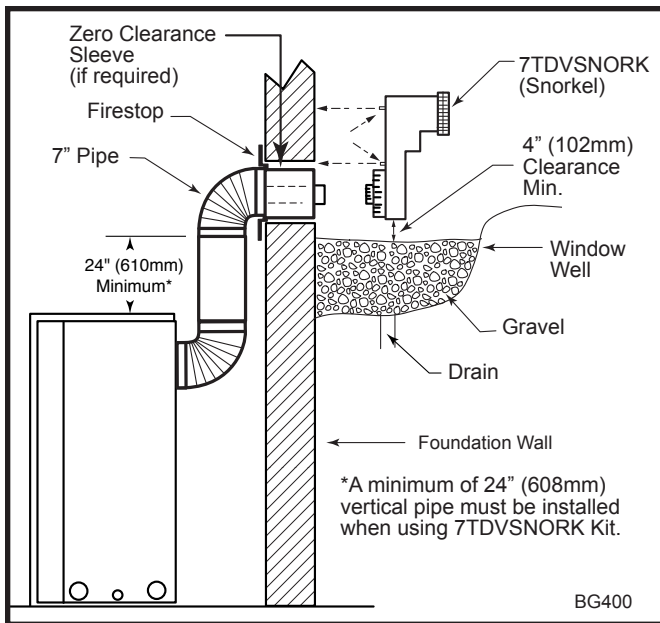

Fig. 31 Below grade installation.

Do not back fill around snorkel. A clearance of at least 4" (102mm) must be maintained between the snorkel and the soil.

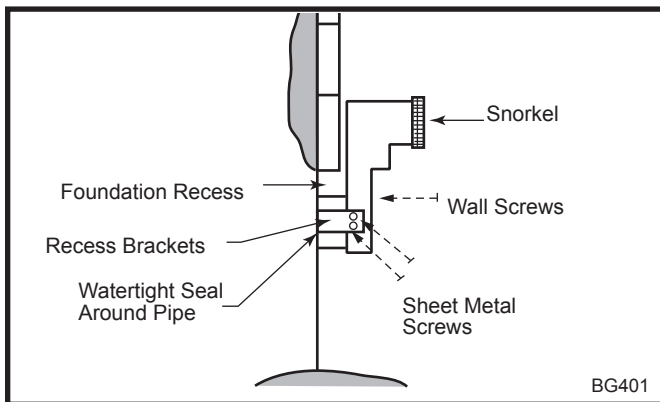

Fig. 32 Snorkel installation, recessed foundation.

If the foundation is recessed, use recess brackets (not supplied) for securing lower portion of the snorkel. Fasten brackets to wall first, then secure to snorkel with self drilling #8 x 1/2 sheet metal screws. It will be necessary to extend vent pipes out as far as protruding wall face. (Fig. 32)

Vertical Through-the-Roof Applications

This Gas Fireplace has been approved for:

1. Vertical installations up to 40' (12 m) in height. Up to 10' (3 m) horizontal vent run can be installed within the vent system using a maximum of three 90° elbows.

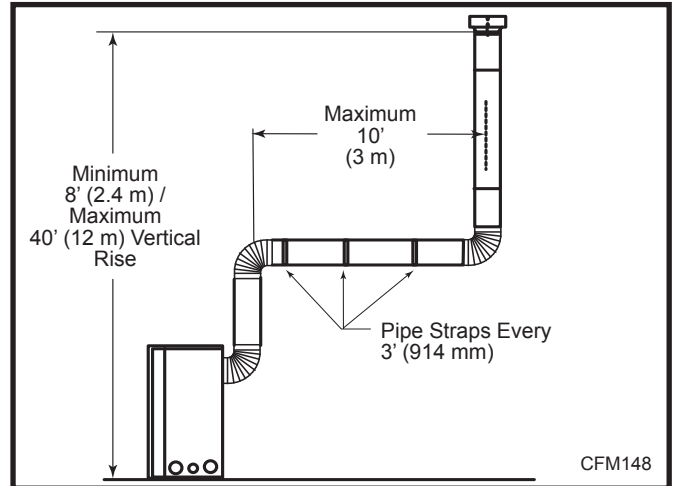

Fig. 33 Support straps for horizontal runs.

This Gas Fireplace has been approved for:

1. Vertical installations up to 40' (12 m) in height. Up to 10' (3 m) horizontal vent run can be installed within the vent system using a maximum of three 90° elbows.
2. Up to two 45° elbows may be used within the horizontal run. For each 45° elbow used on the horizontal level the maximum horizontal length must be reduced by 18" (457 mm).

Example: Maximum horizontal length

- 0 x 45° elbows = 10' (3 m)
- 1 x 45° elbows = 8½' (2.6 m)
- 2 x 45° elbows = 7' (2.1 m)

3. A minimum of an 8' vertical rise.
 4. Two sets of 45° elbows offsets within these vertical installations. From 0 to a maximum of 8' (2.4 m) of vent pipe can be used between elbows. (Fig. 34)
 5. 7DVCS must be used to support offsets. (Fig. 34)
- This application will require that you first determine the roof pitch and use the appropriate 7DVSKV (A, B or F). (Refer to Venting Components List, Page 21)

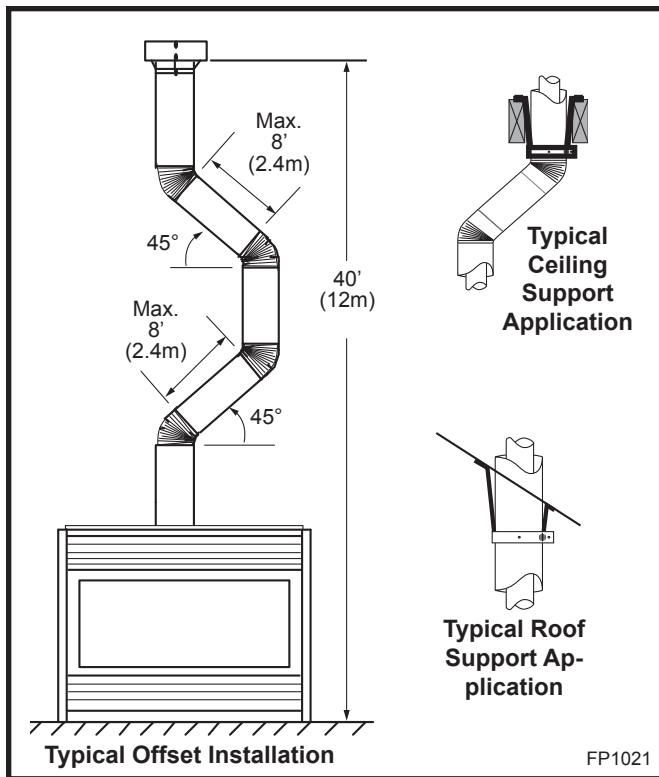

Fig. 34 Typical vertical roof applications.

Vertical Through-the-Roof Installation

1. Locate your fireplace.
2. Plumb to center of the (4") flue collar from ceiling above and mark position.
3. Cut opening equal to 9³/₈" x 9³/₈" (240 x 240mm).
4. Proceed to plumb for additional openings through the roof. In all cases, the opening must provide a minimum of 1 inch clearance to the vent pipe, i.e., the hole must be at least 9³/₈" x 9³/₈" (240 x 240mm).
5. Place fireplace into position.
6. Place firestop(s) #7DVFS or Attic Insulation Shield #7DVAIS into position and secure. (Fig. 35)
7. Install roof support (Fig. 36 & 37) and roof flashing making sure upper flange is below the shingles. (Fig. 36)
8. Install appropriate pipe sections until the venting is above the flashing. (Fig. 36)
9. Install storm collar and seal around the pipe.
10. Add additional vent lengths for proper height. (Fig. 38)
11. Install vertical vent termination.

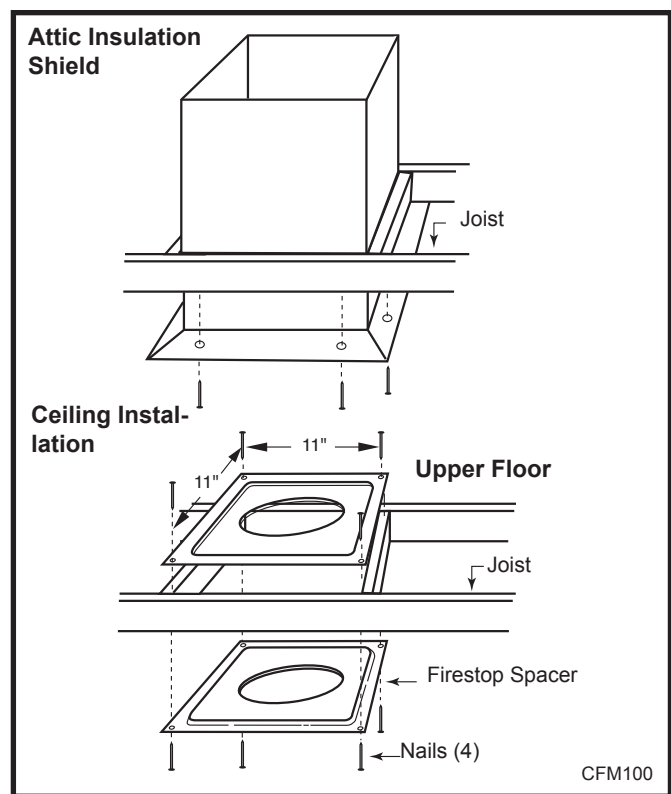

Fig. 35 Place firestop spacer(s) and secure.



If there is room above ceiling level, firestop spacer must be installed on both the bottom and the top side of the ceiling joists. If an attic is above ceiling level a 7DVAIS (Attic Insulation Shield) must be installed. (Fig. 35)



The enlarged ends of the vent section always face downward. (Fig. 36)

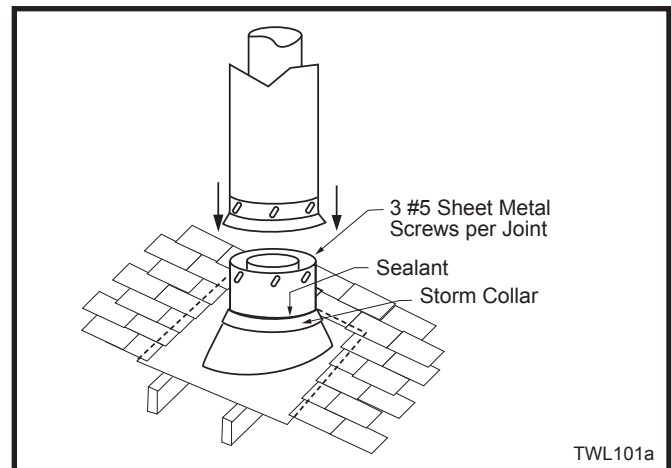

Fig. 36 Roof flashing.

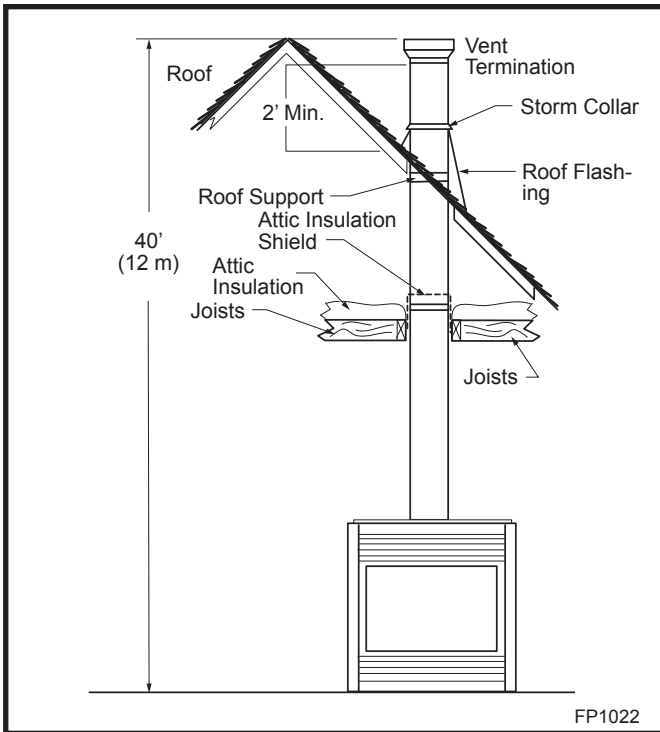

Fig. 37 Typical straight-up installation.

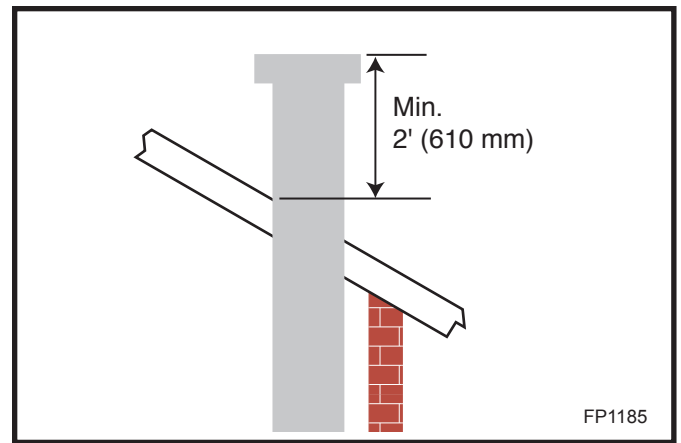
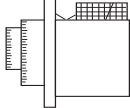
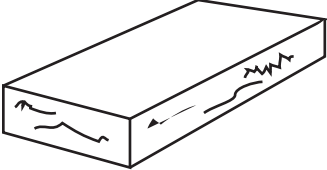
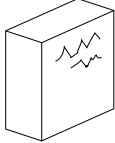
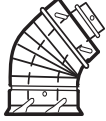

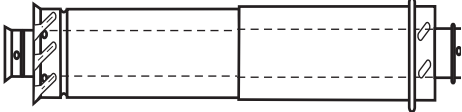

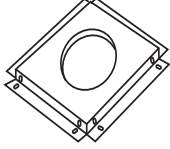
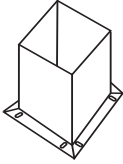



Fig. 38 Minimum termination to roof clearance.

| Venting Components | |
|---|--|
|  | 7TDVRVT - Through the wall Rear Vent Termination |
|  | <p>Starter Kit -</p> <ul style="list-style-type: none"> Model 7TDVSK - Sidewall Venting (Twist Lock Pipe) Model 7FDVSK - Sidewall Venting (Flex Vent Pipe) Models 7TDVTK/TV - Hot Touch Termination Kits Model 7TDVTVTK/TV - Cool Touch Termination Kit <p>Starter Kit - Model 7TDVSKV - Vertical Venting for 7TDVSKV-A order 1/12 to 6/12 roof pitch for 7TDVSKV-B order 7/12 to 12/12 roof pitch for 7TDVSKV-F order flat roof</p> <p>Starter Kit for Below Grade Installation</p> <ul style="list-style-type: none"> Model 7TDVSKS -Snorkel Kit (Twist Lock Pipe) Model 7FDVSKS -Snorkel Kit (Flex Vent Pipe) |
|  | <p>Starter Pipe</p> <ul style="list-style-type: none"> Model 7TDVP 20/8 - 24" Starter Pipe Bulk Model 7FDVP 30/8 - 30" Flex Pipe Bulk |
|  | <p>45° Elbow</p> <ul style="list-style-type: none"> 7TDV45 for Rear Vent to Vertical Vent or Vertical/Horizontal Offsets |
|  | <p>90° Transition Elbow</p> <ul style="list-style-type: none"> 7TDVRT90 for Rear Vent to Vertical Vent <p>90° Elbow</p> <ul style="list-style-type: none"> 7TDV90 Vertical/Horizontal Offset |
|  | <p>Telescopic vent sections</p> <ul style="list-style-type: none"> 7TDVP1117 -11" to 17" adjustable length 7TDVP3567 -35" to 67" adjustable length |
|  | <p>Pipe sections for vertical or horizontal venting</p> <ul style="list-style-type: none"> Model 7TDVP8" - 4 per box Model 7TDVP12" - 4 per box Model 7TDVP24" - 4 per box Model 7TDVP36" Model 7TDVP48" |
|  | <p>Firestop Spacer</p> <ul style="list-style-type: none"> Model 7DVFS |
|  | <p>Attic Insulation Shield</p> <ul style="list-style-type: none"> Model 7DVAIS |
|  | <p>Vertical/Horizontal Combination Offset Support</p> <ul style="list-style-type: none"> Model 7DVCS |

Operating Instructions

Glass Information



Only glass approved by CFM Corporation should be used on this fireplace.

- The use of any non-approved replacement glass will void all product warranties.
- Care must be taken to avoid breakage of the glass.
- **Do not operate appliance with glass front removed, cracked or broken.**
- **Replacement glass (complete with frame window) is available through your CFM Corporation dealer and should only be installed by a licensed qualified service person.**

! WARNING



HOT GLASS WILL CAUSE BURNS.

DO NOT TOUCH GLASS UNTIL COOLED.

NEVER ALLOW CHILDREN TO TOUCH GLASS.

Louvre Removal

The top louvre panel is removed by lifting the panel vertically and pulling it away from the appliance. (Fig. 39) The lower access door is hinged along the bottom edge and is folded down to allow access.

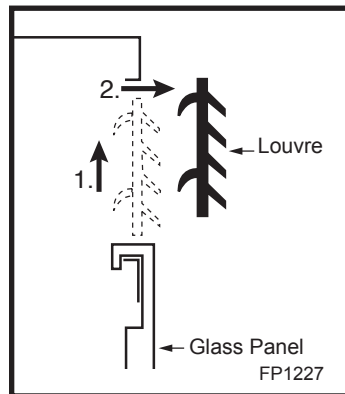

Fig. 39 Remove top louvre assembly.

Window Frame Assembly Removal

1. Turn the fireplace OFF (including the pilot)
2. If the unit has been operating allow time for the components to cool.
3. Remove the top louvre assembly.
4. Open the lower louvre panel.
5. Release the two clamps securing the lower edge of the window frame assembly by pulling down on the handles. (Fig. 40)

6. Tilt the window frame assembly out slightly at the bottom, lift the window frame assembly up and away from the fireplace.
7. To replace the window frame assembly reverse the procedure.

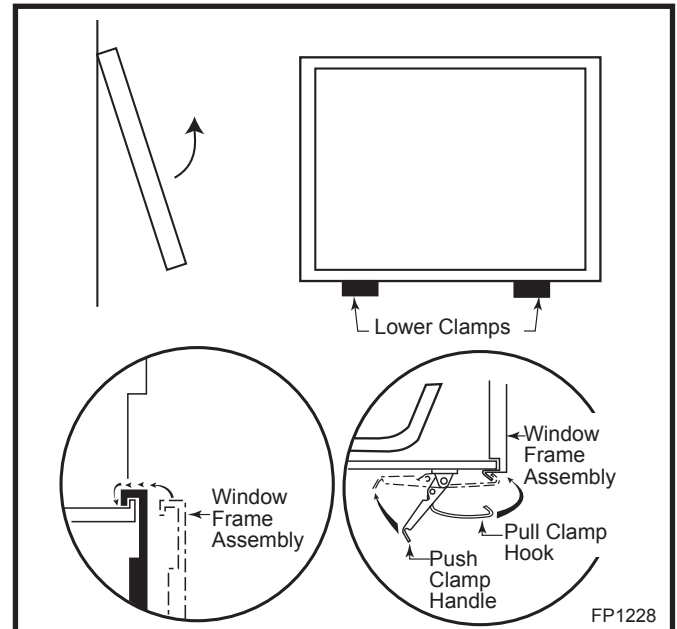

Fig. 40 Window frame assembly removal.

Glass Cleaning

It is necessary to periodically clean glass. During start-up condensation, which is normal, forms on the inside of the glass. This condensation causes lint, dust and other airborne particles to cling to glass surface.

Also initial paint curing may deposit a slight film on the glass. It is therefore recommended the glass be cleaned two or three times with a non-ammonia based household cleaner and warm water (We recommend gas fireplace glass cleaner) within the first few weeks of operation.

After the initial cleaning process the glass should be cleaned two or three times during each operating season depending on the environment in the house.



Clean glass after first two weeks of operation.

Do not clean glass when hot.

Do not use abrasive cleaners.

Do not strike or slam the glass.

Installation of Logs, Lava Rock & Ember Material



The logs are fragile and should be handled with care. Keep the packaging material out of the reach of children and dispose of the material in a safe manner.



The individual logs can be easily identified by the numbers cast on the underside of each log.

Log Identification Chart

| Location | 33LDVR | 36LDVR | 39LDVR | 43LDVR |
|--------------|--------|--------|--------|--------|
| Front Left | A43 | B160 | BC15 | BD16 |
| Front Right | -- | B159 | BC16 | BD17 |
| Front Center | -- | B161 | B138 | B138 |
| Rear | -- | B158 | BC14 | BD15 |
| Rear Left | A41 | -- | -- | -- |
| Rear Right | A42 | -- | -- | -- |
| Top Center | A44 | -- | -- | BD18 |

Log Installation

1. Remove the top louvre assembly.
2. Open the bottom louvre.
3. Remove the window frame assembly.
4. Remove log box from inside firebox.
5. Unpack the logs from packaging and remove each log from its wrapping material. Set aside the ember and the lava rock bags.



As with all plastic bags - these are not toys and should be kept away from children and infants.

33LDVR

1. Place rear log left (A41) on rear bracket (ensure the notch on the left end locates against the bend up on the left side of rear bracket.)
2. Place rear log right (A42) on rear bracket (ensure the notch on the right end locates against the bend up on the right side of rear bracket) and just rest the cut out from front log onto the front support.
3. Place front log left (A43). Use the log's bottom hole to locate it onto rear log left (A41) and just rest bottom cut out log onto the front support.
4. Place top log center (A44). Use the log's bottom hole to locate it onto the knob on the rear log right (A42) and the top log center rest onto rear log left.
5. Place ember material on top of burner. Scatter the ember material over the tiles on the front area of the burner housing. (Fig. 48) Do not pack the ember material. Separate it when unpacked and keep it in a fluffy and loose condition for a more realistic ember effect.
6. Scatter the lava rock material around the firebox base.



Do not place any of the lava rock material on the burner housing assembly.

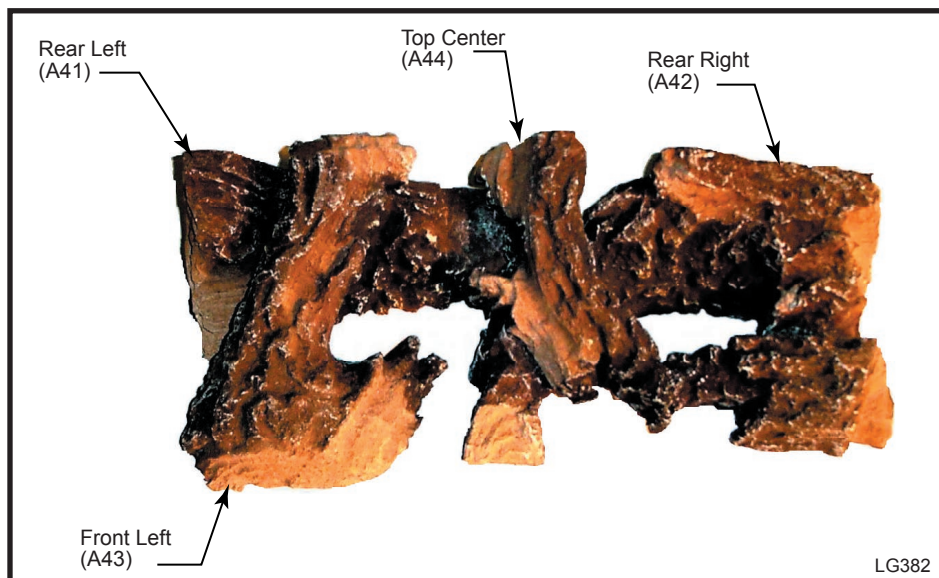

Fig. 41 Correct log placement for 33LDVR.

36LDVR

1. Place rear log (B158) on rear bracket (ensure log is seated properly to the bracket and located to the two pins), so it will not move from side to side and is firmly positioned on the bracket.
2. Place front left log (B160). Use the log's bottom hole to locate it onto the front support and just rest on top of the rear log.
3. Place front right log (B159). Use the log's bottom hole to locate it onto the front support and the top hole to the knob onto the rear log.
4. Place front center log (B161) on top of the two small shelves at the front log support and between the left and right logs.
5. Place ember material on top of burner. Scatter the ember material over the tiles on the front area of the burner housing. (Fig. 49) Do not pack the ember material. Separate it when unpacked and keep it in a fluffy and loose condition for a more realistic ember effect.
6. Scatter the lava rock material around the firebox base.

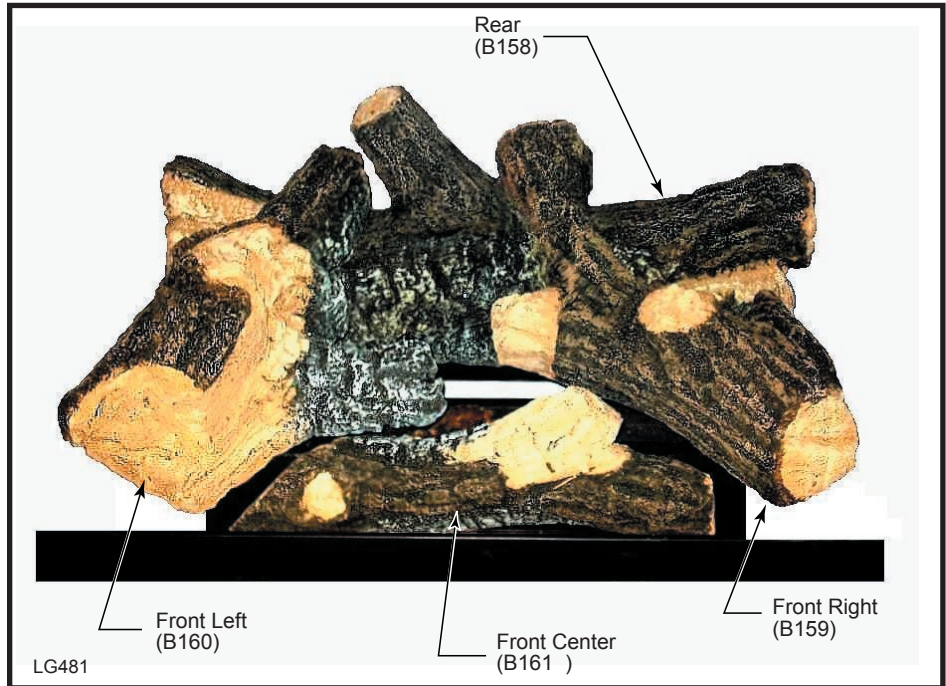

Fig. 42 Correct log placement for 36LDVR.



Do not place any of the lava rock material on the burner housing assembly.

39LDVR

1. Place rear log (BC14) on rear bracket (ensure log is centered and seated properly to the log support).
2. Place front left log (BC15). Use log's bottom hole to locate it onto the front support and just rest on top of the rear log.
3. Place front right log (BC16). Use log's bottom hole to locate it onto the front support and the top hole to the knob on the rear log.
4. Place front center log (B138) on top of the two small shelves at the front log support, and between the left and right logs.
5. Place ember material on top of burner. Scatter the ember material over the tiles on the front area of the burner housing. (Fig. 50) Separate it when unpacked and keep it in a fluffy and loose condition for a more realistic ember effect.

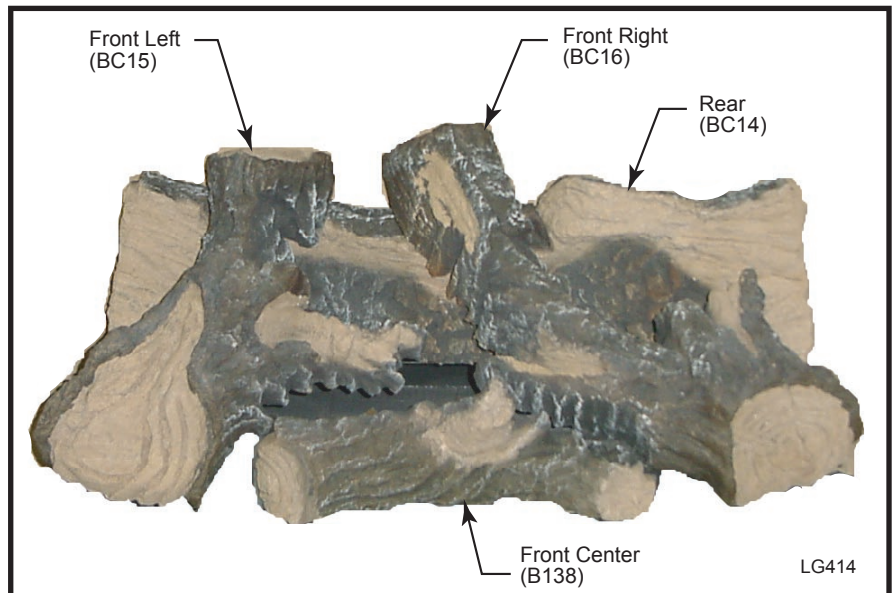

Fig. 43 Correct log placement for 39LDVR.



Do not place any of the lava rock material on the burner housing assembly.

43LDVR

1. Place rear log (BD15) on rear bracket (ensure log is centered and seated properly to the log support).
2. Place front left log (BD16). Use log's bottom notch to locate it onto the front support and just rest on top of the burner housing tile.
3. Place front right log (BD17). Use log's bottom notch to locate it onto the front support and just rest on top of the burner housing.
4. Place ember material on top of burner.
5. Scatter the ember material over the tiles on the front area of the burner housing. (Fig. 44) Do not pack the ember material. Separate it when unpacked and keep it in a fluffy and loose condition for a more realistic ember effect.
6. Place front center log (B138) on top of the two small shelves at the front log support, and between the left and right logs.
7. Place top center log (BD18) on top of the rear log using the hole locator under the log and on top of front right log.
8. Scatter lava rock material round the firebox base.

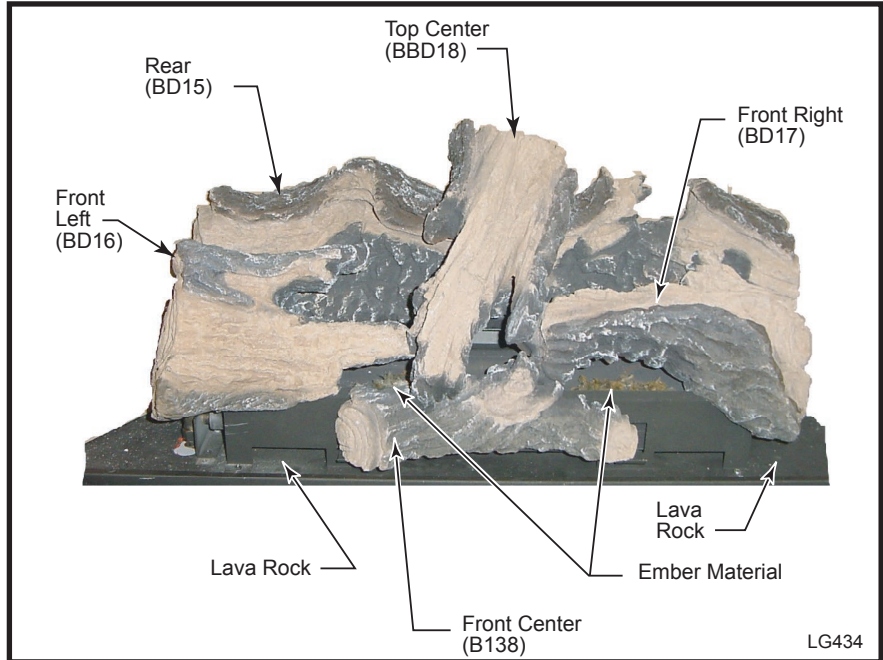

Fig. 44 Correct log placement for 43LDVR.



Do not place any of the lava rock material on the burner housing assembly.

Flame & Temperature Adjustment

RN/RP & EN/EP Models

For units equipped with "HI/LO" valves the flame adjustment is accomplished by rotating the "HI/LO" adjustment knob located near the center of the gas control valve. (Figs. 45 & 46)

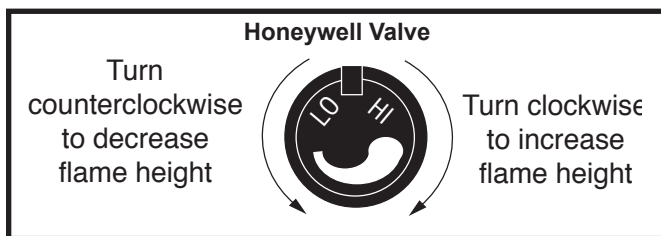

Fig. 45 Flame adjustment knob for Honeywell valve.

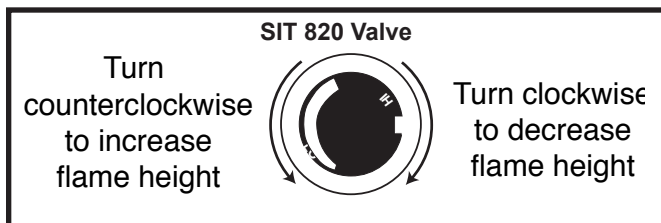

Fig. 46 Flame adjustment knob for SIT valve.

Flame Characteristics

It is important to periodically perform a visual check of the pilot and burner flames. Compare them to the illustrations. (Figs. 47-48)

If the flame patterns appear abnormal contact a qualified service provider for service and adjustment.

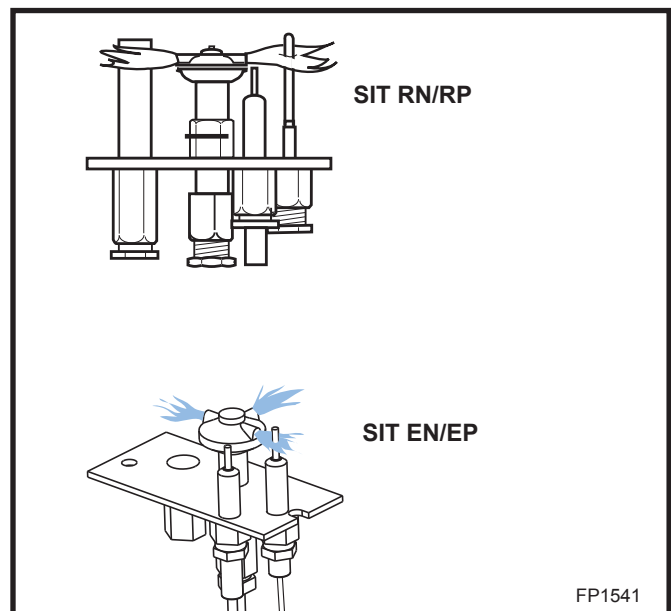

Fig. 47 Correct pilot flame appearance.

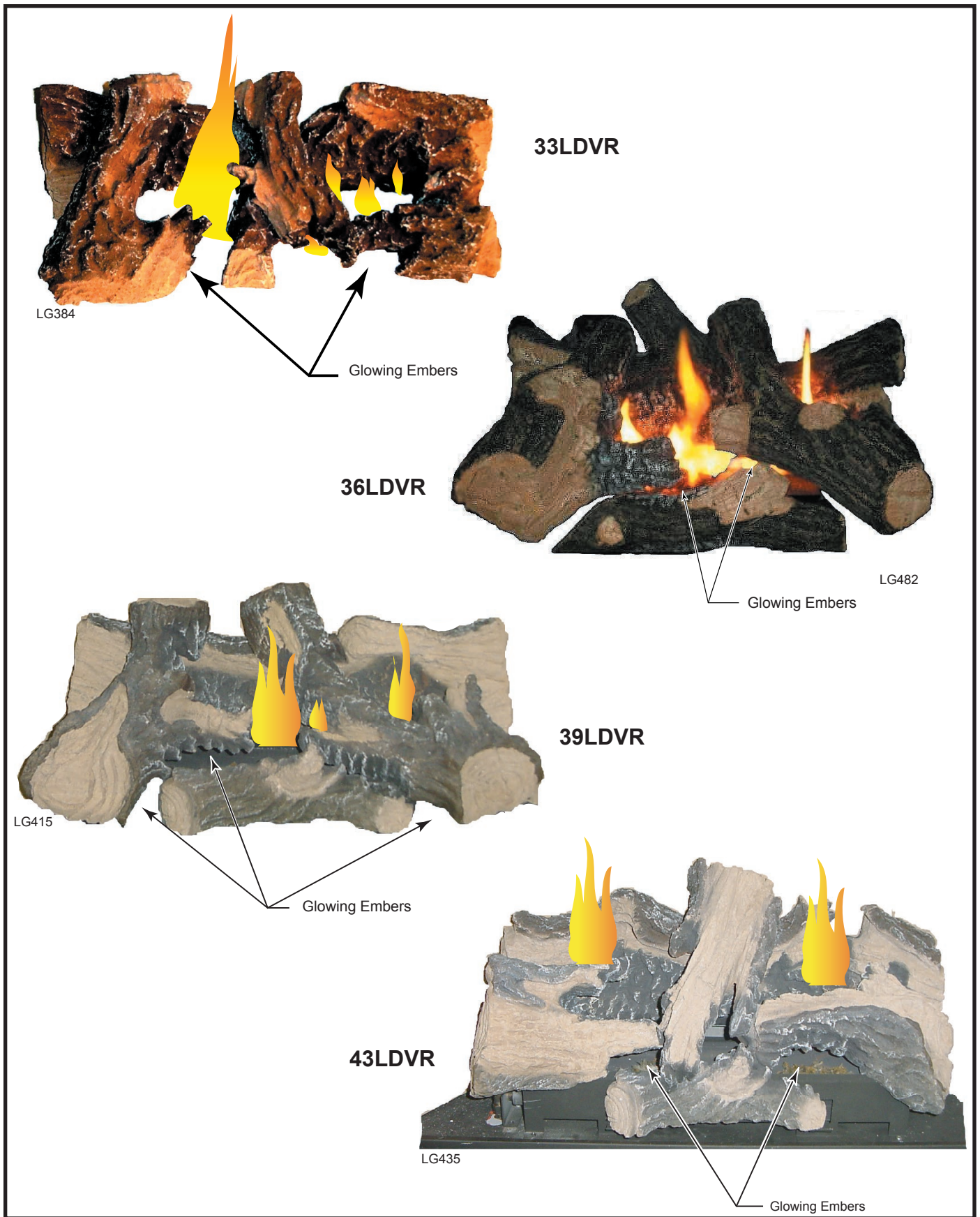

Fig. 48 Correct burner flame appearance for the LDVR fireplaces.

Lighting and Operating Instructions

FOR YOUR SAFETY READ BEFORE LIGHTING

WARNING: If you do not follow these instructions exactly, a fire or explosion may result causing property damage, personal injury or loss of life.

- This heater has a pilot which must be lit manually. When lighting the pilot follow these instructions exactly.
- BEFORE LIGHTING smell all around the heater area for gas. Be sure to smell next to the floor because some gas is heavier than air and will settle on the floor.

WHAT TO DO IF YOU SMELL GAS

- Do not try to light any fireplace
- Do not touch any electric switch
- Do not use any phone in your building
- Immediately call your gas supplier from a neighbor's phone.

Follow the gas supplier's instructions.

- If you cannot reach your gas supplier, call the Fire Department
- Use only your hand to push in or turn the gas control knob. Never use tools. If the knob will not push in or turn by hand, do not try to repair it, call a qualified service technician. Applying force or any attempted repair may result in a fire or explosion.
 - Do not use this fireplace if any part has been under water. Immediately call a qualified service technician to inspect the heater and to replace any part of the control system and any gas control which has been under water.

Lighting Instructions

- STOP!** Read the safety information above.
- Turn off all electrical power to the fireplace.
- For MN/MP/TN/TP appliances ONLY, go on to Step 4. For RN/RP appliances turn the ON/OFF switch to "OFF" position or set thermostat to lowest level.
- Open control access panel.
- Push in gas control knob slightly and turn clockwise  to "OFF".

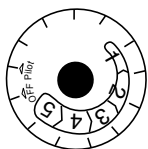

Euro SIT

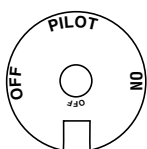

SIT NOVA



Honeywell

- Wait five (5) minutes to clear out any gas. Then smell for gas, including near the floor. If you smell gas, STOP! Follow "B" in the safety information above. If you do not smell gas, go to the next step.
- Remove glass door before lighting pilot. (See Glass Frame Removal section).
- Visibly locate pilot by the main burner.
- Turn knob on gas control counterclockwise  to "PILOT".

- Push the control knob all the way in and hold. Immediately light the pilot by repeatedly depressing the piezo spark ignitor until a flame appears. Continue to hold the control knob in for about one (1) minute after the pilot is lit. Release knob and it will pop back up. Pilot should remain lit. If it goes out, repeat steps 5 through 8.

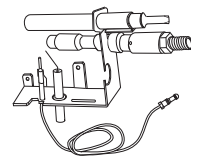
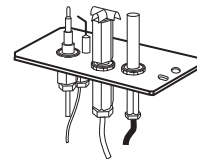
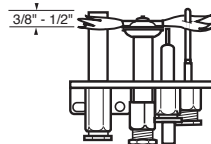

- If knob does not pop up when released, stop and immediately call your service technician or gas supplier.
 - If after several tries, the pilot will not stay lit, turn the gas control knob to "OFF" and call your service technician or gas supplier.
- Replace glass door.
 - Turn gas control knob to "ON" position.
 - For RN/RP appliances turn the ON/OFF switch to "ON" position or set thermostat to desired setting.
 - Turn on all electrical power to the fireplace.

To Turn Off Gas To Heater

- Turn the ON/OFF switch to Off position or set the thermostat to lowest setting.
- Turn off all electric power to the fireplace if service is to be performed.
- Open control access panel.
- Push in gas control knob slightly and turn clockwise  to "OFF". Do not force.
- Close control access panel.

Lighting and Operating Instructions

For Fireplaces equipped with SIT822 Gas Valve (EN or EP)

Warning: If you do not follow these instructions exactly, a fire or explosion may result causing property damage, personal injury and loss of life.

FOR YOUR SAFETY READ THE FOLLOWING WARNINGS BEFORE LIGHTING THE APPLIANCE

A. This fireplace is equipped with an ignition device which automatically lights the pilot. **DO NOT** try to light the pilot by hand.

B. **BEFORE OPERATING**, smell all around the appliance area for gas. Be sure to smell next to the floor because some gas is heavier than the air and will settle on the floor.

What to do if you smell gas

- **Do not try to light any appliance**
- **Do not operate any electrical switch.**
- **Do not use any phone in your building.**
- **Immediately call your gas supplier from a neighbor's phone.**

Follow the gas suppliers instructions.

- **If you cannot contact your gas supplier call the Fire Department**

C. Use only your hand to push in or turn the gas control knob. Never use tools. If the knob will not push in or turn by hand do not try to repair it, call a qualified service technician. Force or attempting repair may result in a fire or explosion.

D. Do not use this appliance if any part has been under water. Immediately call a qualified service technician to inspect the appliance and replace any part of the control system and any gas control that has been under water.

Lighting Instructions

1. **STOP!** Read the safety information above before continuing.
2. Turn off all electrical power to the appliance.
3. This appliance is equipped with an ignition device which automatically lights the pilot. **DO NOT** try to light the pilot by hand.
4. Access the gas control by lowering the lower access door (louvre assembly).

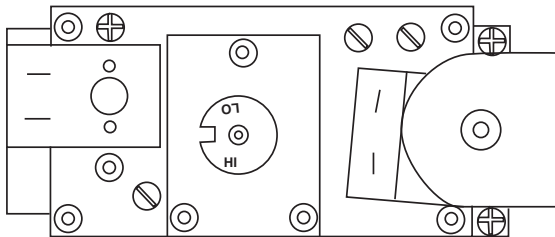

5. Turn the remote switch, if used, OFF. Turn the wireless remote, if used, OFF.
6. Wait five (5) minutes to clear out any gas. Then smell for gas, including near the floor. If you smell gas STOP. Follow instructions B in the safety warnings above. If you do not smell gas go onto the next step.
7. Close the access door.
8. Turn ON all electrical power to the appliance.
9. Turn remote switch or wireless remote to "ON".
10. If the appliance will not operate, follow the instructions TURNING OFF THE GAS TO THE APPLIANCE and call your service technician or gas supplier.

Turning Off the Gas to the Appliance

1. Turn the remote switch to the "OFF" position.
2. Turn OFF all electrical power to the fireplace if service is required.
3. Open the lower access panel.
4. Turn the shut-off valve on the flexible gas line to the "OFF" position.

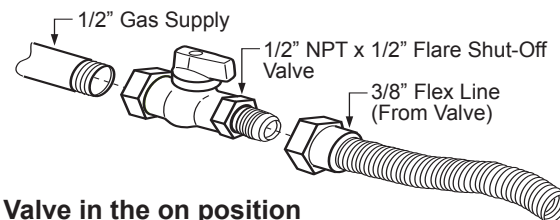

Valve in the on position

Troubleshooting - Honeywell Millivolt Valve



Remove Window Frame Assembly Before Service Work

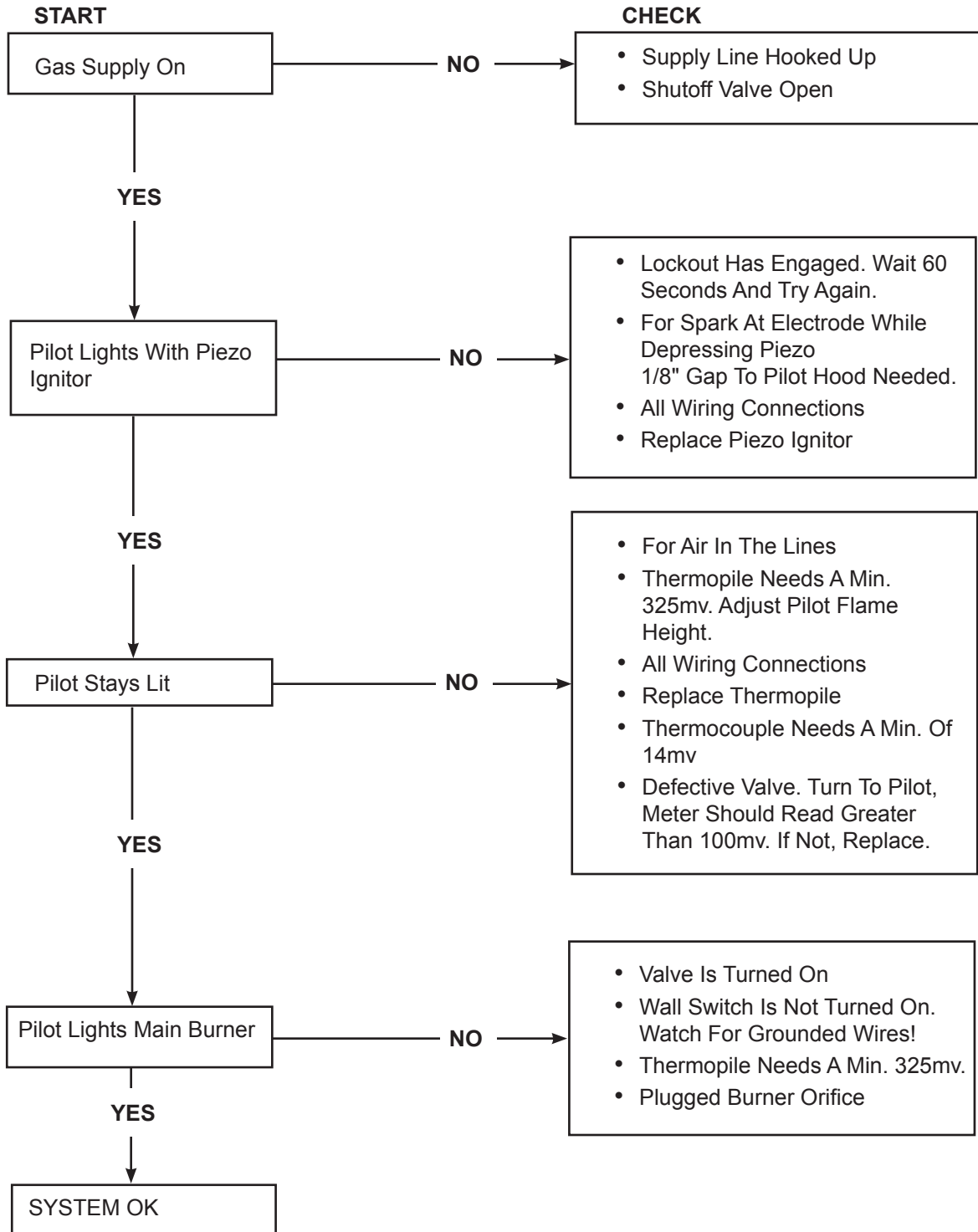

Troubleshooting the Gas Control System

SIT 822 Valve with Synetek Electronic Control
Operating Diagram

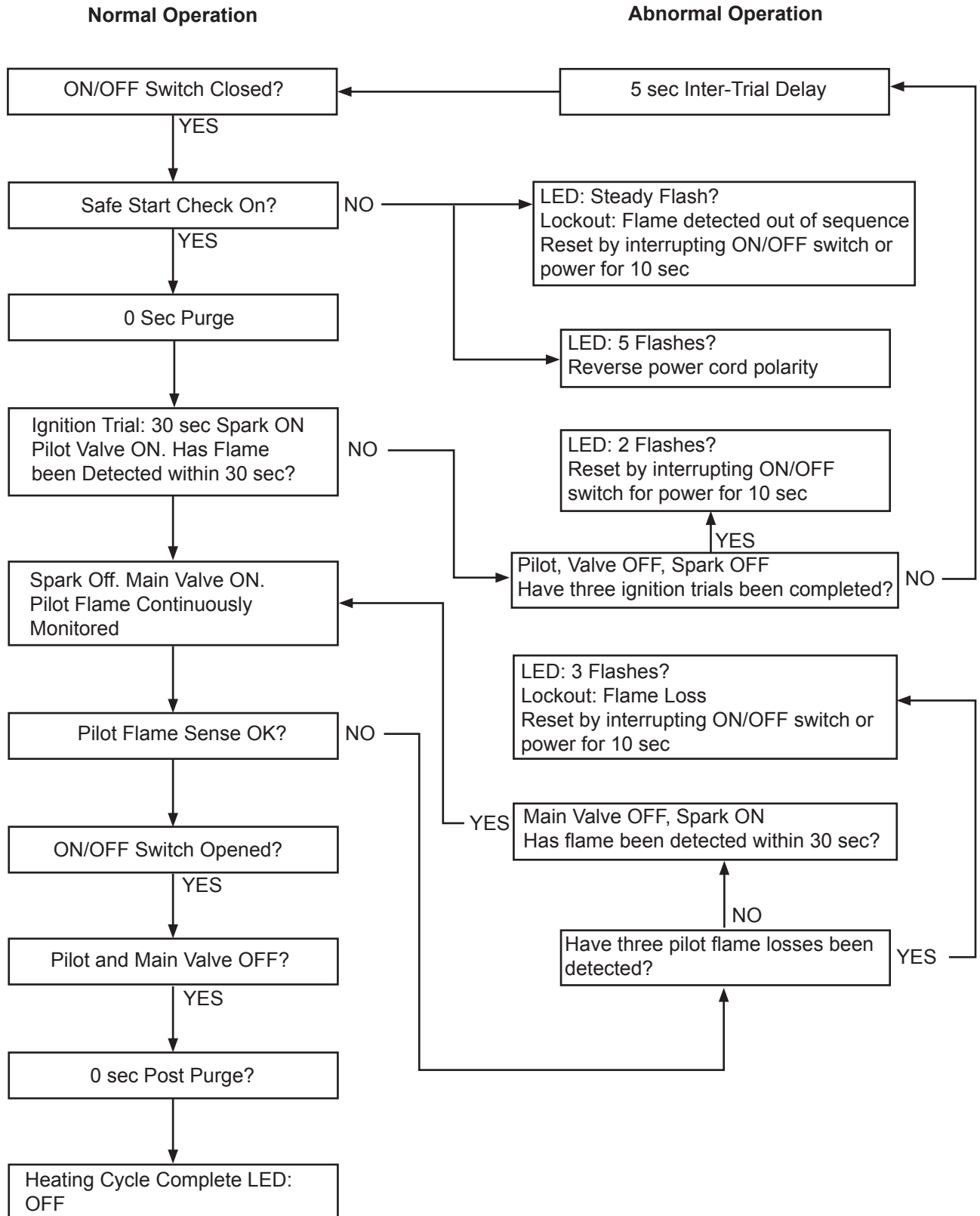

Fuel Conversion Instructions



The conversion of this appliance from one gas to another must be carried out by an authorized service provider.



The procedure for converting from one gas to another is the same regardless of the initial gas used. The only variation is in the orifice sizes and component part numbers. Your authorized service provider will ensure the correct parts are used.

1. Disconnect power to the unit and shut off the gas supply.
2. Remove window frame assembly.
3. Carefully remove the logs & lava rock material.
4. Remove the screws that are holding the burner housing in place.
5. Remove the burner housing assembly. Depending on the model of the appliance you may have to loosen the pilot bracket retaining screw/nut to allow the pilot and bracket assembly to tilt and give enough clearance to remove the burner housing assembly.
6. **For Model 36LDVR ONLY:** Remove the rear log support and relocate the two (2) screws that locate the rear log as shown in Figure 49.

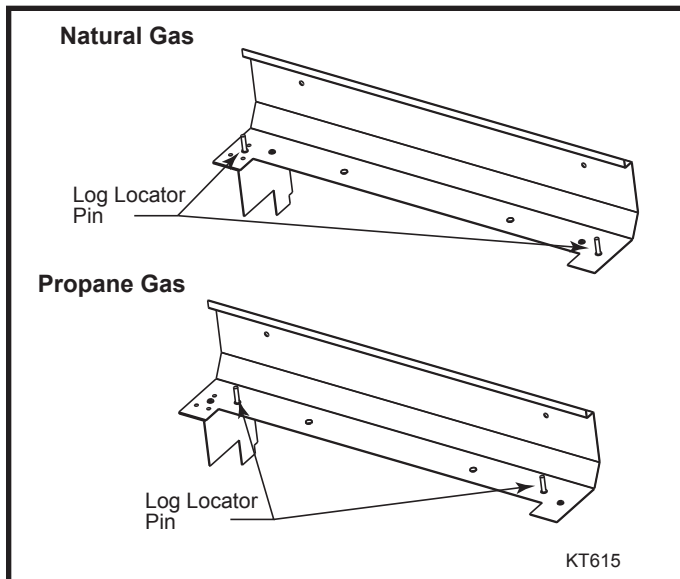

Fig. 49 Move log locator pins to new locations on rear log support.

7. Remove the main burner orifice and replace it with the orifice supplied in the conversion kit.

8. SIT top Convertible Pilot

Gently lift off the pilot hood from the pilot. (Do not remove the spring clip holding the hood in place). Using a 5/32" Allen key, unscrew the exposed orifice. Insert the new orifice supplied in the kit, do not over tighten the orifice. Replace the pilot hood ensuring the index tab aligns with the notch on the hood.

9. PSE Pilot

Using a suitable wrench on the hexagonal body unscrew the pilot hood assembly from the pilot, do not twist the hood itself. Remove the orifice and replace it with the new orifice supplied in the kit. Refit the pilot hood assembly. Do not over-tighten the pilot hood. The hood must return to its original alignment. Take care not to damage the thermocouple, thermopile or igniter.

10. SIT 820 NOVA Gas Control Valve (Fig. 50)

- a. Using a Torx T20 or slotted screwdriver, remove and save the three pressure regulator mounting screws (A), pressure regulator tower (B) and diaphragm (C).

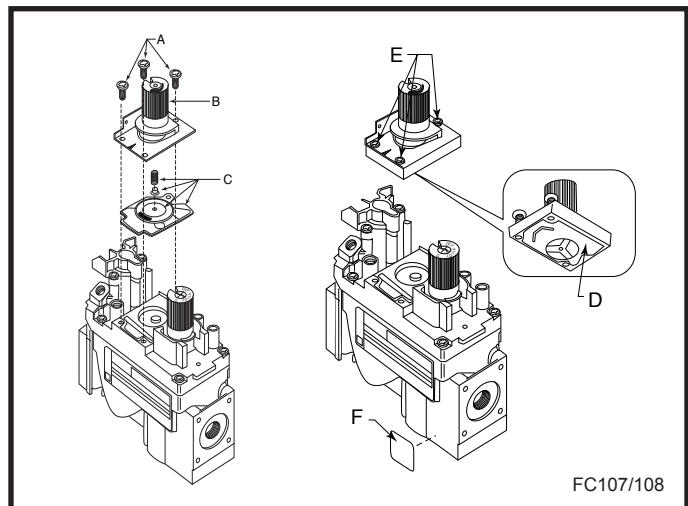

Fig. 50 Nova SIT820 Gas Valve.

- b. Ensure the rubber gasket (D) is properly positioned and install the new HI/LO pressure regulator to the valve using the new screws (E) supplied with the kit. Tighten screws securely. (Reference torque - 25 in.LB)
- c. Install the enclosed identification label (F) to the valve body where it can be easily seen.

Honeywell Gas Control Valve (Fig. 51)

The Honeywell valve fitted to this unit is suitable for use with LP or Natural Gas. It is converted to the required gas application by the installation of a color coded "conversion screw".

- a. Using a suitable small screwdriver lift out the central regulator cap from the "HI/LO" knob on the valve.
 - b. Unscrew the exposed conversion screw.
 - c. Insert the new color coded conversion screw. Do not over-tighten the screw, it must be finger tight.
 - d. Refit the regulator cap.
 - e. Mount conversion label supplied with conversion screw to valve in a visible position.
11. Reassemble the fireplace in the reverse order, except for the window frame assembly. Leave this off until after the unit has been checked for leaks and the gas supply has been bled.

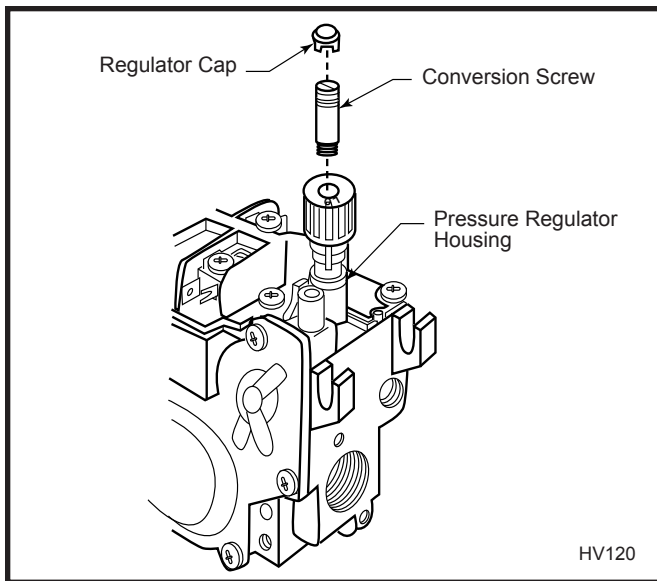

Fig. 51 Honeywell Gas Valve.

12. After bleeding the gas line and checking for leaks with a soap solution, replace the window frame assembly. Fire up the unit, check for flame impingement on the logs, adjusting them if necessary. Check the manifold and supply pressures against the appliance specifications.

Maintenance

Burner and Burner Compartment

It is important to keep the burner and the burner compartment clean. At least once per year the logs and lava rock/ember material should be removed and the burner compartment vacuumed and wiped out. Remove and refit the logs as per the instructions in this manual.



Always handle the logs with care as they are fragile and may also be hot if the fireplace has been in use.

FK24/FK12 Fan Assembly

The fan unit requires periodic cleaning. At least once per month in the operating season open the lower louver panels and wipe or vacuum the area around the fan to remove any build up of dust or lint.

Brass Trim

Clean the brass trim pieces using a soft cloth lightly dampened with lemon oil. Do not use water or household cleaners on any brass components.

Cleaning the Standing Pilot Control System

The burner and control system consist of:

- burner
- gas orifice
- pilot assembly
- thermopile
- millivolt gas valve

Most of these components may require only an occasional checkup and cleaning and some may require adjustment. **If repair is necessary, it should be performed by a qualified technician.**

1. Turn off pilot light at gas valve.
2. Allow fireplace to cool if it has been operating.
3. Remove window frame assembly. (Refer to Window Frame Assembly Removal section.)
4. Remove logs.
5. Vacuum burner compartment especially around orifice primary air openings.
6. Visually inspect pilot. Brush or blow away any dust or lint accumulation.
7. Reinstall logs.
8. Ignite pilot - Refer to Lighting Instructions.
9. Reinstall window frame assembly.

To obtain proper operation, it is imperative that the pilot and burner's flame characteristics are steady, not lifting or floating.

Typically, the top 3/8" to 1/2" of the thermopile should be engulfed in the pilot flame. (Refer to Page 25, Figure 47)

To adjust pilot burner: (by qualified service technician)

1. Remove pilot adjustment cap
2. Adjust pilot screw to provide properly sized flame.
3. Replace pilot adjustment cap.

The primary air shutter is set at factory and should only be adjusted, if necessary, by a qualified service technician.

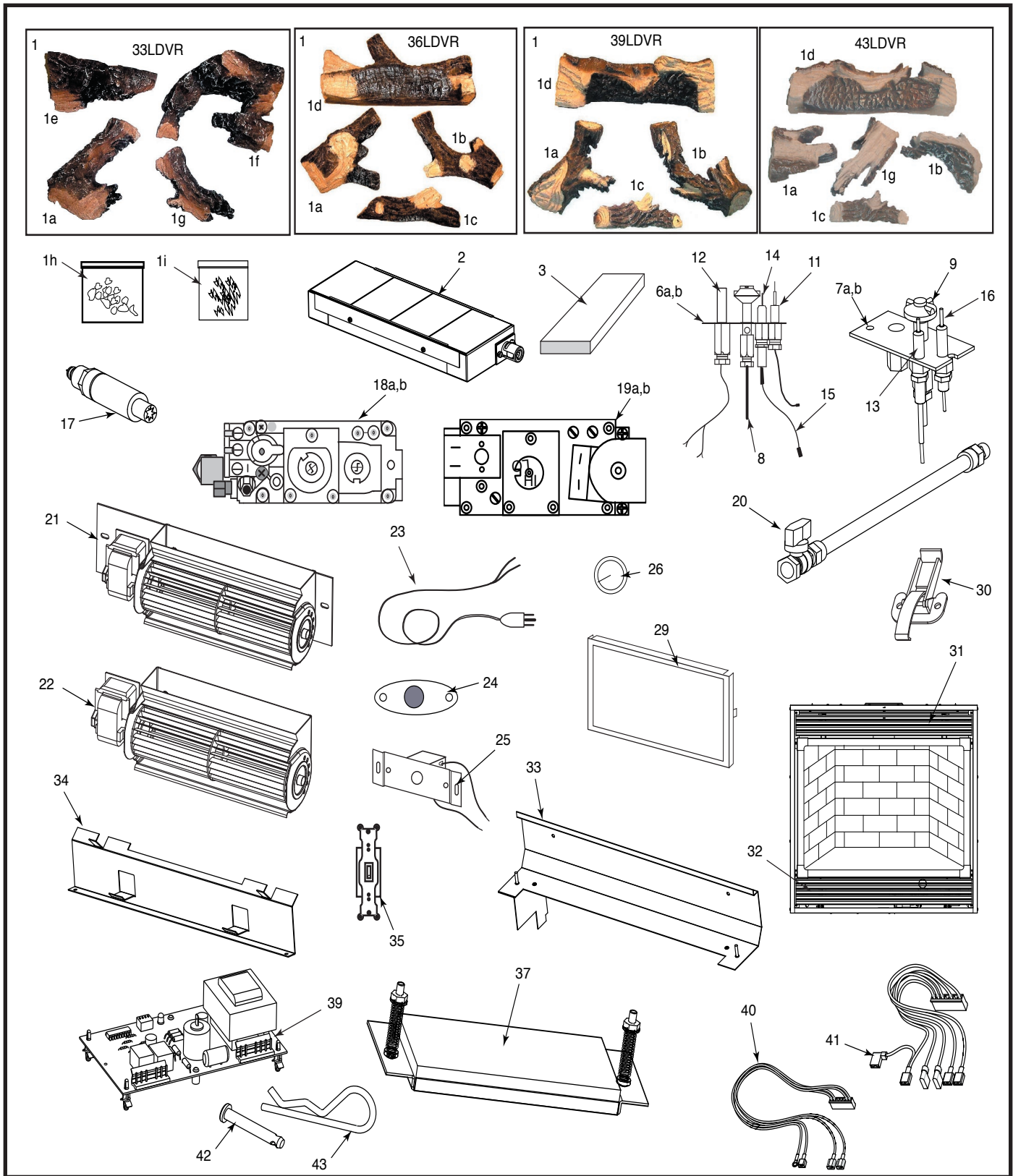

CFM Corporation reserves the right to make changes in design, materials, specifications, prices and discontinue colors and products at any time, without notice.

33/36/39/43LDVR

- 33LDVR units: GFRN210, GFRL210, GFRE210
- 36LDVR units: GFRN2J1, GFRL2J1, GFRE2J1
- 39LDVR units: GFRN2K0, GFRE2K0
- 43LDVR units: GFRN2N0, GFRE2N0

LDVR (continued)

| Ref. | Description | 33LDVR | 36LDVR | 39LDVR | 43LDVR |
|------|---|--|----------|----------|----------|
| 1. | Log Set (complete) | 10007567 | 10010113 | 10008214 | 10008314 |
| 1a. | Front Left Log | A43 | B160 | BC15 | BD16 |
| 1b. | Front Right Log | -- | B159 | BC16 | BD17 |
| 1c. | Front Center Log | -- | B161 | B138 | B138 |
| 1d. | Rear Log | -- | B158 | BC14 | BD15 |
| 1e. | Rear Left Log | A41 | -- | -- | -- |
| 1f. | Rear Right Log | A42 | -- | -- | -- |
| 1g. | Top Center Log | A44 | -- | -- | BD18 |
| 1h. | Lava Rock Package | 10001454 | 10001454 | 10001454 | 10001454 |
| 1i. | Ember (Package) | 51915 | 51915 | 51915 | 51915 |
| 2a. | Burner Housing Assy - Natural | 10007558 | 10007127 | 10008218 | 10008464 |
| 2b. | Burner Housing Assy - LP | 10007558 | 10008042 | 10008586 | 10008587 |
| 3. | Ceramic Tile (Single) | 57803 | 57803 | 57803 | 57803 |
| 4a. | Orifice Burner - Natural | Refer to Rating Plate for Orifice Size | | | |
| 4b. | Orifice Burner - Propane | Refer to Rating Plate for Orifice Size | | | |
| 5a. | Orifice Pilot - Natural | 10002268 | 10002268 | 10002268 | 10002268 |
| 5b. | Orifice Pilot - Propane | 10002269 | 10002269 | 10002269 | 10002269 |
| 6a. | Pilot Assy SIT - RN | 10002264 | 10002264 | 10002264 | 10002264 |
| 6b. | Pilot Assy SIT - RP | 10002265 | 10002265 | 10002265 | 10002265 |
| 7a. | Pilot Assy SIT - EN | 10002387 | 10002387 | 10002387 | 10002387 |
| 7b. | Pilot Assy SIT - EP | 10002388 | 10002388 | 10002388 | 10002388 |
| 8. | Pilot Tubing w/Fittings SIT | 10001296 | 10001296 | 10001296 | 10001296 |
| 9. | Pilot Hood | 10002385 | 10002385 | 10002385 | 10002385 |
| 10. | Manifold Tubing w/Fittings | 57318 | 57318 | 57318 | 57318 |
| 11. | Thermocouple - RN/RP | 53373 | 53373 | 53373 | 53373 |
| 12. | Thermopile - RN/RP | 51827 | 51827 | 51827 | 51827 |
| 13. | Electrode Ignitor w/Cable - RN/RP | 10001297 | 10001297 | 10001297 | 10001297 |
| 14. | Electrode Ignitor - EN/EP | 52465 | 52465 | 52465 | 52465 |
| 15. | Cable Ignitor - EN/EP | 10000696 | 10000696 | 10000696 | 10000696 |
| 16. | Sensing Electrode - EN/EP | 57885 | 57885 | 57885 | 57885 |
| 17. | Ignitor Piezo SIT820 Valve | 52464 | 52464 | 52464 | 52464 |
| 18a. | Valve SIT 820 - RN | 52677 | 52677 | 52677 | 52677 |
| 18b. | Valve SIT 820 - RP | 52678 | 52678 | 52678 | 52678 |
| 19a. | Valve SIT 822 - EN | 57884 | 57884 | 57884 | 57884 |
| 19b. | Valve SIT 822 - EP | 57883 | 57883 | 57883 | 57883 |
| 20. | Flexible Gas Line w/ON/OFF Shut-Off Valve | 20002500 | 20002500 | 20002500 | 20002500 |
| 21. | Fan Assy w/Bracket (FK24 Option) | ZA1100 | ZA1100 | ZA1100 | ZA1100 |
| 22. | Fan Assy (FK12 Option) | ZA1110 | ZA1110 | ZA1110 | ZA1110 |
| 23. | Electrical Cord (6ft) | 51865 | 51865 | 51865 | 51865 |
| 24. | Fan Temperature Sensor (FK24) | 51704 | 51704 | 51704 | 51704 |
| 25. | Speed Control (FK24) | 51738 | 51738 | 51738 | 51738 |
| 26. | Speed Control Knob (FK24) | 51882 | 51882 | 51882 | 51882 |
| 29. | Frame Window w/Glass | 10009693 | 10009694 | 10009695 | 10008535 |
| 30. | Clamp Frame Window | 54174 | 54174 | 54174 | 54174 |
| 31. | Top Louvre Assy | 10007400 | 10007090 | 10007984 | 10008311 |
| 32. | Bottom Louvre Assy | 10007397 | 10007092 | 10007986 | 10008307 |
| 33a. | Support Rear Log | 10007561 | 10007162 | 10008211 | 10008480 |
| 33b. | Support Rear Log - LP | 10007561 | 10008045 | 10008211 | 10008480 |

LDVR (continued)

| Ref. | Description | 33LDVR | 36LDVR | 39LDVR | 43LDVR |
|------|--|----------|----------|----------|----------|
| 34. | Support Front Log | 10007562 | 10007112 | 10008416 | 10008469 |
| 35. | ON/OFF Switch | 51842 | 51842 | 51842 | 51842 |
| 37. | Relief Plate Assy (Burner Base) | 10004192 | 10004192 | 10004192 | 10004192 |
| 38. | Remote Switch Kit (Not shown) | 53875 | 53875 | 53875 | 53875 |
| 39. | Ignition Control from Synetek (EN) | 10007939 | 10007939 | 10007939 | 10007939 |
| 40. | Wire Harness (EN) Synetek (low voltage) | 10008139 | 10008139 | 10008139 | 10008139 |
| 41. | Wire Harness (EN) Synetek (high voltage) | 10008140 | 10008140 | 10008140 | 10008140 |
| 42. | Clevis Pin | 10008615 | 10008615 | 10008615 | 10008615 |
| 43. | Clip Pin Hitch | 10008616 | 10008616 | 10008616 | 10008616 |

Fuel Conversion Kits

Conversion Kit, NG to LP

- 33LDVR Kit # 10008233
- 36LDVR Kit # 10008235
- 39LDVR Kit # 10008237
- 43LDVR Kit # 10008239

Conversion Kit, LP to NG

- 33LDVR Kit # 10008234
- 36LDVR Kit # 10008236
- 39LDVR Kit # 10008238
- 43LDVR Kit # 10008240

Optional Accessories Available

Fan Kits

FK24 Fan Assembly

This auxiliary fan system increases the efficiency of the circulation of the heated air.

The FK24 fan kit allows variable speed control of the circulation fan and also incorporates a heat sensor in the circuit.

Specifications

115 Volt / 60Hz / 56 Watts

Maintenance

The fan itself does not require regular maintenance, however periodic cleaning of the fan and the surrounding area is required.

Check the area under the control door (lower louvre assembly) and in front of the fan and wipe or vacuum this area at least once a month during the operating season.

Installation

The fan assembly and other components are supplied fully wired, eliminating the need for a licensed electrician to carry out the installation.

If hard wiring the fan using Method B (following) we strongly recommend the use of a licensed electrician.

1. Open the lower louvre assembly. Move the fan & bracket assembly around the gas valve and lines to locate the unit onto the screw studs on the back of the fireplace.
2. Install the thermal sensor under the bottom of the of the firebox, locating it over the two 10mm studs and secure it with nuts.
3. Locate the fan speed control unit. This can be fitted behind the lower louvre assembly as in Figure 52 or located remotely in a conveniently located wall mounted electrical box. Remote location of the speed control will require suitable extension of the component wiring.
4. The power supply may be connected in two ways:

Method A

Route the 6' lead fitted to the unit to a conveniently located wall socket.

Method B (Using EB-1 Receptacle Box)

The EB-1 receptacle box (Pt. # ZA1200) may be hard wired into the house supply. The fan lead is then plugged into the EB-1 box. For instruction on wiring the EB-1 receptacle box see the earlier chapter in the Installation section of this manual.

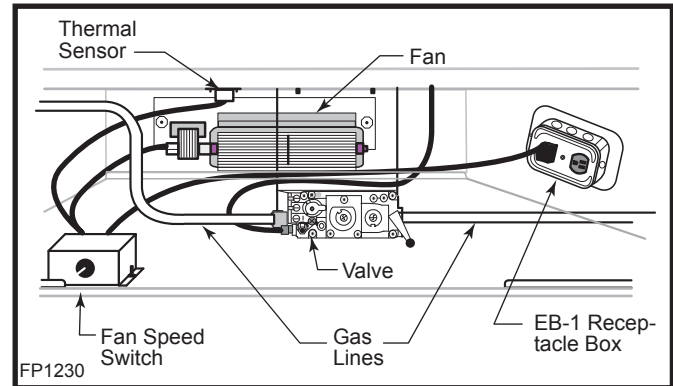

Fig. 52 FK24 fan placement.

FK12

This auxiliary fan system increases the efficiency of the circulation of the heating air.

The FK12 Fan Assembly is a fixed speed fan system and does not allow for variable speed control. It does not use the speed control unit or the heat sensor used in the FK24 Kit.

Specifications

115 Volts / 60 Hz / 56 Watts.

Maintenance

The fan itself does not require regular maintenance, however periodic cleaning of the fan and the surrounding area is required.

Check the area under the control door (lower louvre assembly) and in front of the fan and wipe or vacuum this area at least once a month during the operating season.

Installation

The fan assembly is supplied fully wired eliminating the need for a licensed electrician to carry out the installation.

1. Open the lower Louvre assembly. Move the fan & bracket assembly around the gas valve and lines to locate the unit against the back wall of the appliance, resting on the base.
2. With the protective cover removed from the self-adhesive 'Velcro' strips apply mild pressure to the fan & bracket unit to secure the strips to the metal panels. No further securing is required.
3. Power to the fan can be supplied by plugging the supplied lead into a conveniently located wall socket or by using a hard-wired EB-1 receptacle box.

Wiring Instructions



The fireplace, when installed, must be electrically connected and grounded in accordance with local codes or, in the absence of local codes, with the current CSA C22.1 Canadian Electric Code.



For USA installations follow the local codes and the national electrical code ANSI/NFPA No. 70.



Should this fan require servicing or repair the power supply must be disconnected. For rewiring of any replacement parts refer to Figure 53.



Any electrical rewiring of this fan must be done by a licensed electrician.

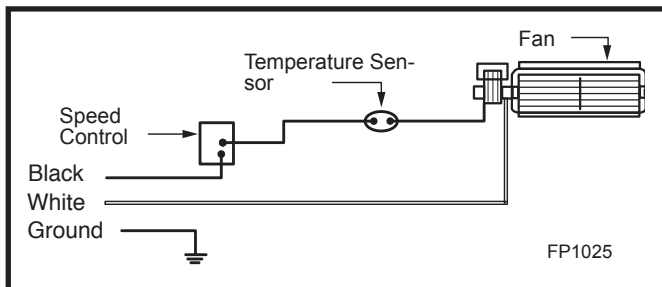

Fig. 53 FK24 fan wiring.

Ceramic Refractory Panels

Ceramic refractory panels are available in kit form for the LDV series appliances

| Unit | Kit Model and Finish | | | |
|--------|----------------------|---------|---------|---------|
| | Sandstone | Red | Black | Grey |
| 33LDVR | 33LDVRCR | | | |
| 36LDVR | GAHC3J0 | GAFC3J0 | GABC3J0 | GAGC3J0 |
| 39LDVR | 39LDVCR | | | |
| 43LDVR | 43LDVCR | | | |



Take care when handling the refractory panels as they are fragile until held in place and supported.

Installation Refer to Figures 54 & 55

1. Remove the front window frame assembly.
2. Remove the logs.
3. Place the rear refractory panel in place. Locate the lower edge of the panel in the ledge formed by the top of the rear log support bracket.
4. Slide the side refractory panels into place to hold the rear panel secure. Repeat the procedure on the other side.
5. Replace the logs and window frame assembly.

For aesthetic purposes we recommend aligning the horizontal mortar lines.

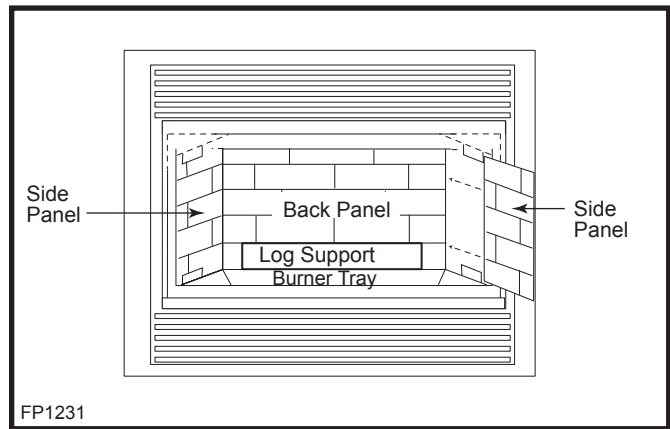

Fig. 54 Ceramic panel installation.

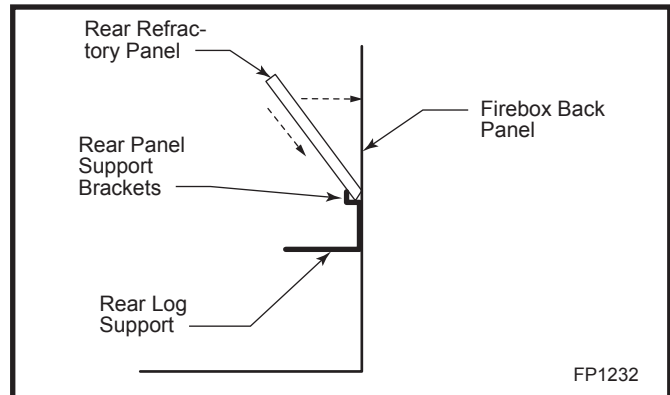

Fig. 55 Rear refractory panel installation.

Remote Controls

Optional remote control units are available to control different functions of the appliances

| Model | Function/s Controlled |
|-------|---|
| RC1 | ON/OFF |
| RC2 | ON/OFF and Temperature |
| IMTFK | Wall mounted thermostat control (must be used in bedroom installations) |

Optional Trim Kits

Louvre Accent Trim

| Appliance Model | Main Louvre Kit | Additional Louvre |
|-----------------|-----------------|-------------------|
| Polished Brass | | |
| 36LDVR | 36DVLMP | 36DVLAP |
| 39LDVR | 39DVLMP | 39DVLAP |
| Rustic Bronze | | |
| 33LDVR | 33DVLMP | 33DVLAR |
| 36LDVR | 36DVLMP | 36DVLAR |
| Pewter | | |
| 33LDVR | 33DVLMS | 33DVLAS |
| 36LDVR | 36DVLMS | 36DVLAS |
| 39LDVR | 39DVLMS | 39DVLAS |
| 43LDVR | 43DVLMS | 43DVLAS |

Regular Trim Kit

| Appliance Model | Trim Kit | |
|-----------------|----------|---------------|
| 33LDVR | 33DVRRK | Pewter |
| 33LDVR | 33DVRTKR | Rustic Bronze |

Adjustable Regular Trim Kit

| Appliance Model | Trim Kit | |
|-----------------|----------|---------------|
| 36LDVR | ADVRRKS | Pewter |
| 36LDVR | ADVRTKR | Rustic Bronze |
| 39LDVR | ADVRRKS | Pewter |
| 39LDVR | ADVRTKR | Rustic Bronze |

Medium Trim Kit

| Appliance Model | Trim Kit | |
|-----------------|----------|--------|
| 33LDVR | 33DVMTKS | Pewter |
| 33LDVR | 33DVMTKB | Black |

Adjustable Medium Trim Kit

| Appliance Model | Trim Kit | |
|-----------------|----------|----------------|
| 36LDVR | ADVMTKP | Polished Brass |
| 36LDVR | ADVMTKS | Pewter |
| 36LDVR | ADVMTKB | Black |
| 39LDVR | ADVMTKP | Polished Brass |
| 39LDVR | ADVMTKS | Pewter |
| 39LDVR | ADVMTKB | Black |

Screen Door Kit

| Appliance Model | Kit Model | |
|-----------------|-----------|---------------|
| 33LDVR | 33DVSDKS | Pewter |
| 36LDVR | 36DVSDKS | Pewter |
| 33LDVR | 33DVSDKB | Black |
| 36LDVR | 36DVSDKB | Black |
| 39LDVR | 39DVSDKB | Black |
| 36LDVR | 36DVSDKR | Rustic Bronze |

Filigree Louvre Kit

| Appliance Model | Kit Model | |
|-----------------|-----------|---------------|
| 33LDVR | 33DVFKB | Black |
| 36LDVR | 36DVFKB | Black |
| 36LDVR | 36DVFKS | Pewter |
| 36LDVR | 36DVFKR | Rustic Bronze |

Arch/Square Face Kit

for the 36LDVR

| | | |
|---------------------|-----------|---------------|
| Romanesque - Arch | | |
| | 36DVARFKB | Black |
| | 36DVARFKR | Rustic Bronze |
| | 36DVARFKS | Pewter |
| Romanesque - Square | | |
| | 36DVSRFKB | Black |
| | 36DVSRFKR | Rustic Bronze |
| | 36DVSRFKS | Pewter |
| Marquette - Arch | | |
| | 36DVAMTKB | Black |
| | 36DVAMTKR | Rustic Bronze |
| | 36DVAMTKS | Pewter |
| Marquette - Square | | |
| | 36DVSMTKB | Black |
| | 36DVSMTKR | Rustic Bronze |
| | 36DVSMTKS | Pewter |

LIMITED LIFETIME WARRANTY

PRODUCT COVERED BY THIS WARRANTY

All Vermont Castings gas stoves, gas inserts, and gas fireplaces, and all Majestic brand gas fireplaces equipped with an Insta-Flame Ceramic Burner, or standard steel tube burner.

BASIC WARRANTY

CFM Corporation (hereinafter referred to collectively as the Company) warrants that your new Vermont Castings or Majestic Gas Fireplace/Stove is free from manufacturing and material defects for a period of one year from the date of purchase, subject to the following conditions and limitations.

EXTENDED LIFETIME WARRANTY

The heat exchanger, where applicable, and combustion chamber of every Vermont Castings or Majestic gas product is warranted for life against through wall perforation. All appliances equipped with an Insta-Flame Ceramic Burner have limited lifetime coverage on the ceramic burner plaque. Warrantees are made to the original owner subject to proof of purchase and the conditions and limitations listed on this Warranty Document

COMPONENT WARRANTY

CAST IRON: All external and internal cast iron parts are warranted for a period of three years.

Note: On porcelain enamel finished external parts and accessories The Company offers no Warranty on chipping of enamel surfaces. Inspect all product prior to accepting it for any damage to the enamel.

The salt air environment of coastal areas or a high humidity environment can be corrosive to the porcelain enamel finish. These conditions can cause rusting of the cast iron beneath the porcelain enamel finish, which will cause the finish to flake off.

Dye lot variations with replacement parts and/or accessories can occur and are not covered by warranty.

GLASS DOORS: Glass doors are covered for a period of one year. Glass doors are not warranted for breakage due to misuse or accident. Glass doors are not covered for discoloration or burned in stains due to environmental issues, or improper cleaning and maintenance.

BRASS PLATED PARTS AND ACCESSORIES: Brass parts should be cleaned with Lemon oil only. Brass cleaners cannot be used. Mortar mix and masonry cleaners may corrode the brass finish. The Company will not be responsible for, nor will it warrant any brass parts which are damaged by external chemicals or down draft conditions.

GAS VALVES: Gas valves are covered for a period of one year

ELECTRONIC AND MECHANICAL COMPONENTS: Electronic and mechanical components of the burner assembly are covered for one year. All steel tube burners are warranted for one year.

ACCESSORIES: Unless otherwise noted all components and CFM Corporation company supplied accessories are covered for a period of one year.

CONDITIONS AND LIMITATIONS

- This Vermont Castings or Majestic product must be installed or serviced by a qualified installer, preferably NFI or WETT (Canada) certified, as prescribed by the local jurisdiction. It must be installed and operated at all times in accordance with the Installation and Operating instructions furnished with the product. Any alteration, willful abuse, accident, or misuse of the product shall nullify this warranty.
- This warranty is non-transferable, and is made to the original owner, provided that the purchase was made through an authorized supplier of the Company.
- The customer must pay for any Authorized Dealer in-home travel fees or service charges for in-home repair work. It is the dealers option whether the repair work will be done in the customer's home or in the dealer's shop.
- If upon inspection, the damage is found to be the fault of the manufacturer, repairs will be authorized at no charge to the customer parts and/or labor.

- Any part and/or component replaced under the provisions of this warranty is covered for six months or the remainder of the original warranty, whichever is longest.
- This warranty is limited to the repair of or replacement of part(s) found to be defective in material or workmanship, provided that such part(s) have been subjected to normal conditions of use and service, after said defect is confirmed by the Company's inspection.
- The company may, at its discretion, fully discharge all obligations with respect to this warranty by refunding the wholesale price of the defective part(s)
- Any installation, labor, construction, transportation, or other related costs/expenses arising from defective part(s), repair, replacement, or otherwise of same, will not be covered by this warranty, nor shall the Company assume responsibility for same. Further, the Company will not be responsible for any incidental, indirect, or consequential damages except as provided by law.
- *SOME STATES DO NOT ALLOW FOR THE EXCLUSION OR LIMITATIONS OF INCIDENTAL AND CONSEQUENTIAL DAMAGES OR LIMITATIONS ON HOW LONG AN IMPLIED WARRANTY LASTS, SO THE ABOVE LIMITATIONS MAY NOT APPLY TO YOUR CIRCUMSTANCES. THIS WARRANTY GIVES YOU SPECIFIC RIGHTS AND YOU MAY HAVE OTHER RIGHTS WHICH VARY FROM STATE TO STATE.*
- All other warranties-expressed or implied- with respect to the product, its components and accessories, or any obligations/liabilities on the part of the Company are hereby expressly excluded.
- The Company neither assumes, nor authorizes any third party to assume on its behalf, any other liabilities with respect to the sale of this Vermont Castings or Majestic product
- The warranties as outlined within this document do not apply to chimney components or other non CFM Corporation accessories used in conjunction with the installation of this product..
- Damage to the unit while in transit is not covered by this warranty but is subject to claim against the common carrier. Contact the dealer from whom you purchased your fireplace/stove (do not operate the appliance as this might negate the ability to process the claim with the carrier).
- The Company will not be responsible for:
 - a) Down drafts or spillage caused by environmental conditions such as near-by trees, buildings, roof tops, hills, or mountains.
 - b) Inadequate ventilation or negative air pressure caused by mechanical systems such as furnaces, fans, clothes dryers, etc.
- This warranty is void if:
 - a) The fireplace has been operated in atmospheres contaminated by chlorine, fluorine, or other damaging chemicals.
 - b) The fireplace has been subjected to prolonged periods of dampness or condensation
 - c) Any damages to the fireplace, combustion chamber, heat exchanger or other components due to water, or weather damage, which is the result of but not limited to, improper chimney/venting installation.
 - d) Any alteration, willful abuse, accident, or misuse of the product has occurred.

IF WARRANTY SERVICE IS NEEDED...

- 1) Contact your supplier. Make sure you have your warranty, your sales receipt, and the model/serial number of your CFM Corporation product.
- 2) DO NOT ATTEMPT TO DO ANY SERVICE WORK YOURSELF.

Canada

ENERGUIDE

Look for the **EnerGuide**
Gas Fireplace Energy
Efficiency Rating in this brochure

Based on CSA P.4.1-02

Efficiency Ratings

| Model | EnerGuide Ratings Fireplace Efficiency (%) | Steady State (%) | | D.O.E. (AFUE%) |
|----------|---|------------------|--------|-------------------|
| | | Fan-OFF | Fan-ON | |
| 33LDVRRN | 62.6 | 81 | 82 | 59 |
| 33LDVRRP | 62.6 | 82 | 83 | 59 |
| 33LDVREN | 72.7 | 81 | 82 | 59 |
| 33LDVREP | 72.7 | 82 | 83 | 59 |
| 36LDVRRN | 57.5 | 81 | 82 | 58 |
| 36LDVRRP | 57.5 | 82 | 83 | 58 |
| 36LDVREN | 63.6 | 81 | 82 | 58 |
| 36LDVREP | 63.6 | 82 | 83 | 58 |
| 39LDVRRN | 50.2 | 76 | 79 | 63 |
| 39LDVRRP | 50.2 | 79 | 80 | 63 |
| 39LDVREN | 54.2 | 78 | 79 | 63 |
| 39LDVREP | 54.2 | 79 | 80 | 63 |
| 43LDVRRN | 54.3 | 77 | 78 | 63 |
| 43LDVRRP | 54.3 | 78 | 79 | 63 |
| 43LDVREN | 58.3 | 77 | 78 | 63 |
| 43LDVREP | 58.3 | 78 | 79 | 63 |

NATIONAL
FIREPLACE
INSTITUTE



CERTIFIED
www.nficertified.org

We recommend that our gas hearth products be installed and serviced by professionals who are certified in the U.S. by the National Fireplace Institute® (NFI) as NFI Gas Specialists.

CFM Corporation

2695 Meadowvale Blvd. • Mississauga, Ontario, Canada L5N 8A3
800-668-5323 • www.cfmcorp.com